



SELECTED PROCEEDINGS

WEATHER ADAPTIVE TRAFFIC PREDICTION USING NEURO-WAVELET MODELS

STEPHEN DUNNE, TRINITY COLLEGE DUBLIN, IRELAND
BIDISHA GHOSH, TRINITY COLLEGE DUBLIN, IRELAND. (BGHOSH@TCD.IE) (+353-1-896 3646)

This is an abridged version of the paper presented at the conference. The full version is being submitted elsewhere. Details on the full paper can be obtained from the author.

ISBN: 978-85-285-0232-9

13th World Conference
on Transport Research

www.wctr2013rio.com

15-18
JULY
2013
Rio de Janeiro, Brazil

unicast

WEATHER ADAPTIVE TRAFFIC PREDICTION USING NEURO-WAVELET MODELS

Stephen Dunne¹, Bidisha Ghosh^{2}*

1. Trinity College Dublin, Ireland

2. Trinity College Dublin, Ireland. (bghosh@tcd.ie) (+353-1-896 3646)

ABSTRACT

Climate change is a prevalent issue facing the world today. Unexpected increase in rainfall intensity and events is one of the major signatures of climate change. Rainfall influences traffic conditions and in turn traffic volume in urban arterials. For improved traffic management under adverse weather conditions, it is important to develop traffic prediction algorithm considering the effect of rainfall. This inclusion is not intuitive as the effect is not immediate and the influence of rainfall on traffic volume is often unrecognizable in a direct correlation analysis between the two time-series datasets; it can only be observed at certain frequency levels. Accordingly, it is useful to employ a multiresolution prediction framework to develop a weather adaptive traffic forecasting algorithm. Discrete Wavelet Transform (DWT) is a well-known multiresolution data analysis methodology. However, DWT imparts time-variance in the transformed signal and makes it unsuitable for further time-series analysis. Therefore, the stationary form of DWT known as Stationary Wavelet Transform (SWT) has been used in this paper to develop a neuro-wavelet prediction algorithm to forecast hourly traffic flow considering the effect of rainfall. The proposed prediction algorithm has been evaluated at two urban arterial locations in Dublin, Ireland. The study shows that the rainfall data successfully augments the traffic flow data as an exogenous variable in periods of inclement weather, resulting in accurate predictions of future traffic flow at the two chosen locations. The forecasts from the neuro-wavelet model outperform the same from the standard Artificial Neural Network (ANN) model.

Keywords: Traffic Flow Forecasting, Weather Adaptive Algorithms, Stationary Wavelet Transform, Artificial Neural Networks, Autocorrelation Function.

INTRODUCTION

Intelligent Transportation Systems (ITS) is a broad spectrum of advanced technologies designed to improve sustainability in existing transportation network by improving efficiency of traffic operationalization and management. An important aspect of ITS is Advanced Traffic Management Systems (ATMS) and for ATMS to function efficiently, information about the actual and the near-term future traffic state is critical. This necessitates the ability to make and continuously update predictions of traffic flows into the future [1], [2]. Traffic flow prediction has become an active field of research over the last fifteen years.

There exists numerous parametric and non-parametric approaches for predicting traffic flow in short-term future. The predominant non-parametric approach, studied in the existing literature on traffic flow forecasting, is the Artificial Neural Network (ANN) algorithms. Conventional ANN structures, such as the Feed Forward Back Propagation Neural Network (FFBPNN) algorithm have been utilized widely by researchers to predict traffic flow in short-term future [3]-[6]. Apart from the conventional ANN, usage of non-conventional ANN structures [7], such as time-delayed ANN [8], recurrent neural networks [9] and genetically optimized neural networks [10], [11], are well-known in this field. Hybrid ANN structures (ANN structures used in conjunction with other signal processing algorithms) are also well-known for their applicability in traffic flow predictions. Spectral basis ANN [12], ANN combined with a fuzzy modeling approach involving Kalman filtering [13], ANN combined with principal component analysis [14] and pattern-based ANN [15] are a few examples of such studies. The different structures and applications of ANN in traffic forecasting have established the versatility of these models compared to other existing methodologies. Due to their ability to predict precisely, to adapt and to be flexible for use in both univariate and multivariate paradigms, the ANN algorithms have been chosen for modeling traffic flow in this paper. A comprehensive review of the different approaches and applications of ANN in traffic prediction is provided in [16].

The Wavelet Transform (WT) [17], [18] is a popular signal processing technique which has been used in conjunction with ANN for various purposes in transportation research. One of the first instances of the use of WT combined with ANN in the transportation field is the work on utilization of Discrete Wavelet Transform (DWT) for data filtering to improve the performance of a neuro-fuzzy ANN incident detection algorithm [19]. Other examples include developing a wavelet energy algorithm featuring Radial Basis Function Neural Network (RBFNN) for fast incident detection on rural and urban roads [20] and using WT with Recurrent Neural Networks (RNN) for online modeling and control of traffic flow [21]. In transportation literature WT has been mainly employed as a denoising procedure as the coefficients generated using DWT are non-stationary in nature and hence the regular time-series prediction algorithms cannot be used successfully with DWT coefficient data series. To eliminate the problem of non-stationarity in time-series datasets decomposed using DWT, a novel redundant WT (also

referred to in the literature as nondecimated WT, stationary WT (SWT) or a-trous algorithm) has been introduced by researchers in different fields [22], [23]. In summary, the trend in recent years has been to use SWT, a stationary version of the DWT, to develop robust and efficient time-series prediction algorithms. This relatively new trend is well developed, as seen in references [22]-[24], and the variety of fields in which it has been successfully implemented displays the model's generalizability. In the field of traffic flow forecasting, SWT has been used for denoising traffic volume time-series data from highways, prior to prediction with self-organizing ANN [24]. However, the multiresolution structure of SWT, involving independent modeling of the higher and lower resolution components, has yet to be exploited in an urban arterial traffic prediction framework.

In this paper, the multiresolution structure of SWT is used to its fullest potential in developing a weather adaptive neuro-wavelet traffic forecasting algorithm which takes into account the effect of weather at different resolution levels. The effect of rain on travel demand and traffic accidents has been confirmed [25]. The study illustrated that rain had a very real effect on travel demand, with the demand decreasing with increasing rain and it was also determined that there are more accidents during rainy conditions. Findings in a technical report [26] identify that adverse weather reduces the capacities and operating speeds on roadways, resulting in congestion and productivity loss. With regards to weather conditions affecting lane speed, an investigation determined that the variation of lane speed is different in fine and adverse weather conditions [27]. The effect of weather on traffic congestion has also been investigated and it was found that rain had a clear extend effect on morning peak congestion [28]. It has also been determined that including the effects of weather in ARIMA forecasting models can result in improvements in forecast accuracy [29]. These conclusions suggest that rain has a definite impact on traffic flow. In this regard, it was thought of as imperative to develop a traffic flow forecasting model that takes into account the weather conditions of the forecasted time interval. It is urgent to develop this model because the presence of climate change decrees that many locations around the world will experience longer and more intense periods of inclement weather. Therefore, with the likelihood of more regular precipitation in many areas, it is necessary to be able to factor in the effect of various levels of precipitation on traffic flow conditions. In this work, the effect of rainfall on traffic volume has been investigated at different resolution levels and incorporated in the prediction model accordingly.

The work in this paper is organized into four sections. Following the introduction in Section 1, Section 2 describes the multiresolution weather adaptive traffic prediction methodology including the theory behind the SWT and ANN algorithms. Section 3 discusses the traffic flow and precipitation data used in modeling along with the results of the prediction algorithms. The paper is concluded in Section 4.

Methodology

This section contains a brief description of the theory behind SWT and ANN algorithms used in this paper and a detailed description of the proposed neuro-wavelet prediction framework.

Theoretical Background

SWT has been used to decompose hourly traffic flow and rainfall time-series datasets. ANN based prediction algorithms were used to predict the traffic flow time-series in near future. Section 2.1.1 covers the SWT theory, while the ANN structure is discussed in section 2.1.2.

Stationary Wavelet Transform

The discrete wavelet transform (DWT) (Mallat, 1989) is a WT with a discrete-time mother wavelet, a non-zero integer dilation (scale) parameter and a discrete translational parameter. Generally in DWT, the dilation parameter is a power of 2 indicating dyadic scales. The DWT of a time-series signal, $x(t)$, can be approximately described as the discretized form of the following:

$$W(a,b) = \langle x(t), \psi_{a,b}(t) \rangle \quad (1)$$

where, $\psi_{a,b}(t)$ is a discrete wavelet, the dilation parameter $a = 2^j$ and the translation parameter $b = 2^j k$. The discrete wavelet $\psi_{j,k}(t)$ can be defined as,

$$\psi_{j,k}(t) = 2^{-j/2} \psi(2^{-j}t - k) \quad (2)$$

Here, j denotes the scale and k denotes the position. In DWT the time-series or the signal is essentially simultaneously filtered through a high-pass and a low-pass filter in this process. The low-pass filter produces the approximation coefficients and the high-pass filter produces the detail components. Any low-pass filter which satisfies certain conditions can be considered as a scaling function and the scaling function, $\phi(t)$, can be convolved with the signal, $x(t)$, to produce the approximation coefficients,

$$c_j(k) = \langle x(t), \phi_{j,k}(t) \rangle = \int_{-\infty}^{\infty} x(t) 2^{-j/2} \phi(2^{-j}t - k) dt \quad (3)$$

Similarly, the detail coefficients generated by filtering through the high-pass filter can be defined as,

$$d_j(k) = \langle x(t), \psi_{j,k}(t) \rangle = \int_{-\infty}^{\infty} x(t) 2^{-j/2} \psi(2^{-j}t - k) dt \quad (4)$$

The original time-series signal can be represented as,

$$x(t) = \sum_{k=-\infty}^{\infty} c_{j_0}(k) \phi_{j_0,k}(t) + \sum_{j=-\infty}^{j_0} \sum_{k=-\infty}^{\infty} d_j(k) \psi_{j,k}(t) \quad (5)$$

In the multiresolution analysis, the approximation component at level j , c_j , can be further decomposed into the approximation and detail components at the next level, $j+1$. Equation (6) display the formulae required for extending the coefficient calculation at further decomposition levels for the approximation and detail cases respectively.

$$c_{j+1}(k) = \sum_{n=-\infty}^{\infty} h_0(n-2k)c_j(n) \quad (6)$$

$$\text{and, } d_{j+1}(k) = \sum_{n=-\infty}^{\infty} h_1(n-2k)c_j(n)$$

$$\phi(t) = \sqrt{2} \sum_{n \in \mathbb{Z}} h_0(n)\phi(2t-n) \quad (7)$$

$$\text{and, } \psi(t) = \sqrt{2} \sum_{n \in \mathbb{Z}} h_1(n)\phi(2t-n)$$

At each level of decomposition, convolution of the approximation coefficients at the previous level with the time reversed filters, $h_0(-n)$ and $h_1(-n)$, followed by downsampling produces the approximation and detail coefficients at the next level respectively (equation 7). Approximation and detail coefficients (c_j and d_j) of a signal $x(t)$ are not the same length as the original signal. For a finite even-length $h_0(n)$,

$$h_1(n) = (-1)^n h_0(N-n) \quad (8)$$

where, N is any odd number; the high-pass and the low-pass filters are in reverse order and in alternate signs. These filters can be called quadrature mirror filters.

In a DWT, $x(t)$ is convolved with filters and then decimated. This decimation removes the time-invariant structure. At every step of the decimation process, either the odd indexed elements or the even indexed elements are chosen and the rest is discarded. However, synthesizing the approximation and details components, or the inverse DWT (see, equation 5) removes the time-variance introduced through downsampling.

The presence of downsampling in DWT means that the time-invariant structure of the time-series, $x(t)$, is altered through the transform. However, for all practical time-series modeling related purposes it is important to achieve or retain the stationarity property of the signal. Therefore, methods were devised to incorporate the property of shift-invariance in WT. To retain the time invariance structure of the dataset, DWT can be performed without decimations through the algorithm proposed by Nason et al. [30] and this transform is termed as SWT (or ε -decimated WT, or shift-invariant WT). The SWT structure is shown in Fig. 1, where time-invariant coefficients are produced in a similar fashion as DWT without any decimation operation.

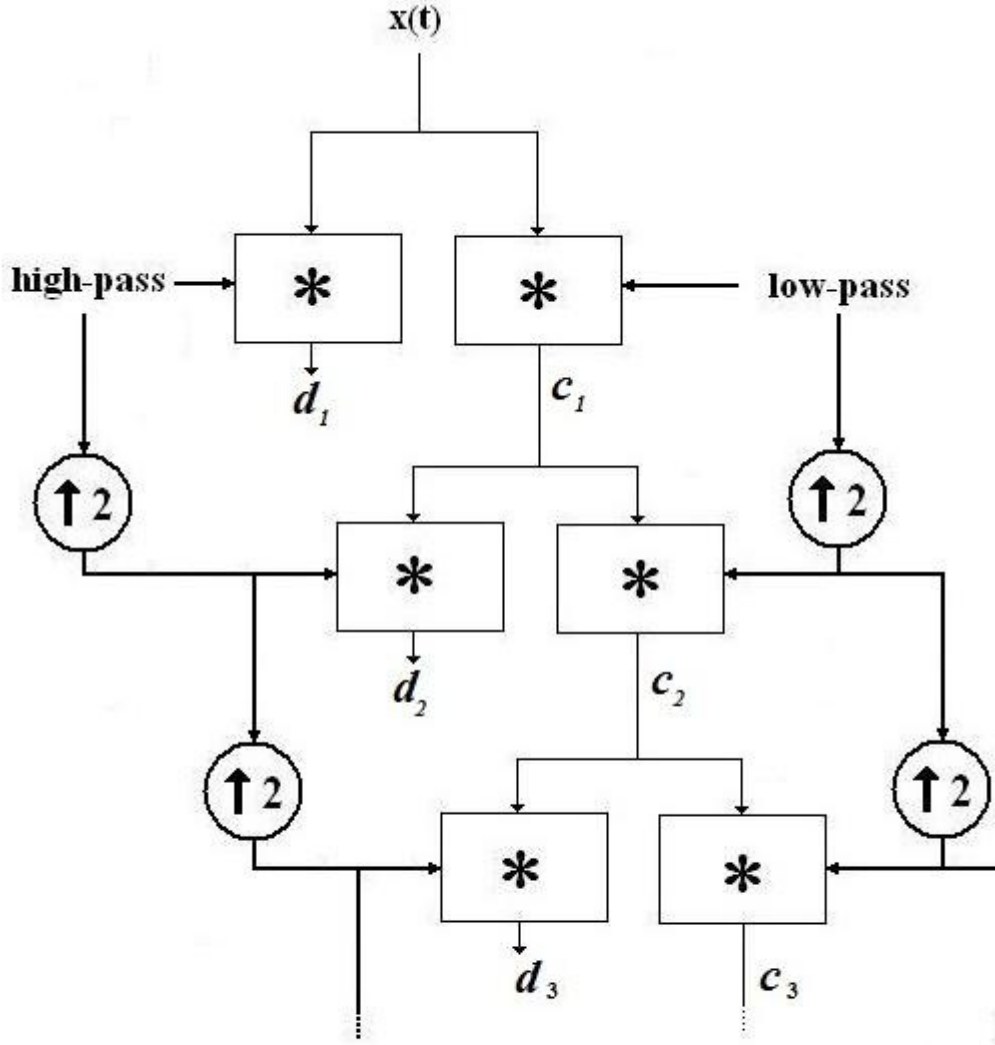

where: * = convolution & ↑2 = upsampling

Figure 1 - Stationary Wavelet Transform Decomposition Tree

The SWT is obtained by convolving the signal $x(t)$ with the appropriate filters as in the DWT but without downsampling. Equation (9) represents the process of generating up-sampled approximation and detail coefficients through SWT.

$$\tilde{c}_{j+1}(k) = \sum_{l=-\infty}^{\infty} h_0(l) \tilde{c}_j(k + 2^j l)$$

$$\text{and, } \tilde{d}_{j+1}(k) = \sum_{l=-\infty}^{\infty} h_1(l) \tilde{c}_j(k + 2^j l) \quad (9)$$

The approximation and the details coefficient obtained through SWT can be synthesized through Inverse SWT (ISWT) to reconstruct the original signal. The crucial result of this is that

the coefficients of the approximation and detail at each level are the same length as the original signal. For further details on SWT, [30] can be consulted for a thorough description of the mathematical theory.

Artificial Neural Network Algorithm

ANN is a statistical data mining tool which involves a network structure inspired by the biological neural networks [31]-[33]. A brief description of this ANN structure is provided here. ANN generally consists of a set of inputs or input vectors (N), which are then multiplied by a set of weights, to generate a net input. A bias is added to the net input and the result is put through an activation function to produce an output from the network. The ANN algorithm used in this paper follows a FFBPNN structure with a unique input vector formulation. The FFBPNN structure was chosen as it shows comparable accuracy with other more complex NN structures [34]. Therefore, to improve the ease and speed of development, FFBPNN was used in this paper without compromising on accuracy compared to more complex NN structures. FFBPNN consist of both a forward and backward phase. Firstly, the Feed Forward (FF) phase involves the network receiving the input data and passing it to the hidden layer of the network. The input vector of the FFBPNN structure in this paper was generated using an autocorrelation based variable reduction technique. The process involves plotting autocorrelation coefficients against time lag for a stationary traffic flow time-series (to ensure stationarity, the mean is first subtracted from each observation of the traffic flow time-series to be analyzed). These autocorrelation coefficients measure the correlation between observations at different lags and provide useful descriptive information about the properties of the time-series data. The lag points with high autocorrelation values were chosen as the most influential data points to be used to predict traffic flow in the future. It is expected that these are the points which have the most influence on the near-term future prediction of traffic flow data. Output values are calculated by summing up the weighted inputs of the input layer and passing these summations through the activation function, a log-sigmoid function in this case. After the forward pass of the inputs, the Back Propagation (BP) phase of the network compares the calculated network outputs, a_{pq} , with the desired or target values, t_{pq} , and is an iterative optimization of the error function that represents the performance of the network. This function of error, E, is defined as

$$E = 0.5 \left(\sum_{p=1}^{MN} \sum_{q=1}^N (t_{pq} - a_{pq})^2 \right) \quad (10)$$

The partial derivative of this error function gives a direction of steepest descent and from this, the corrections to the weights of the network are determined for each iteration. In summary, a difference between the network output and the target output results in the gradient descent algorithm adjusting the connection weights (w_1, w_2, \dots, w_{MN}) of the network, in an attempt to bring future network outputs more in line with the desired outputs i.e. teaching the network.

The Levenberg-Marquardt (LM) algorithm [35], [36] is used with the FFBPNN in this paper as to optimize the error function. This algorithm is an iterative optimization technique that locates the minimum of a multivariate non-linear function. Rewriting the standard FFBPNN error function as a function of the weights of the network results in Equation 11:

$$f(\mathbf{W}) = \frac{\mathbf{E}^T \mathbf{E}}{2} = \frac{\mathbf{E}^T (\mathbf{W}) \mathbf{E}^T (\mathbf{W})}{2} = \frac{1}{2} \sum_{p=1}^{MN} \sum_{q=1}^N (t_{pq} - a_{pq})^2 \quad (11)$$

where $\mathbf{W} = [w_1, w_2, \dots, w_p]^T$, $\mathbf{E} = [e_{11}, \dots, e_{MNN}]$

The weight updation is then achieved as,

$$\mathbf{W}(k+1) = \mathbf{W}(k) - (\mathbf{J}_k^T \mathbf{J}_k)^{-1} \mathbf{J}_k^T \mathbf{E}_k \quad (12)$$

where the Jacobian matrix \mathbf{J} , contains the first derivatives of the network errors with respect to weights and biases, and \mathbf{E} is a vector of network errors. $\mathbf{J}^T \mathbf{J}$ is positive definite, but if it is not, then some perturbations made into it control the probability of it being non-positive. Thus,

$$\mathbf{W}(k+1) = \mathbf{W}(k) - (\mathbf{J}_k^T \mathbf{J}_k + \lambda \mathbf{I})^{-1} \mathbf{J}_k^T \mathbf{E}_k \quad (13)$$

The quantity λ is a learning parameter which decreases as the iterative process approaches to a minimum.

In summary, the ANN model in this work uses autocorrelated input vectors as input to a FFBPNN structure with LM algorithm applied for training. Therefore, the forecasts in this work are computed using an input dataset composed of previous observations which are highly correlated with the recent data. This framework hugely improves the computation time of the network as the size of the input vector, and hence the number of neurons in the network setup, is reduced considerably [34]. Hereafter, this FFBPNN structure involving autocorrelated input vector has been labeled as Autocorrelation Neural Network (ACNN).

Neuro-Wavelet Prediction Framework

A schematic of the prediction framework is shown in Fig. 2. The proposed framework uses SWT to decompose traffic flow and precipitation time-series data into approximation and detail components. These components are then predicted individually using separate ACNN models, with the forecasted components then recombined using an inverse SWT (ISWT). This recombined and reconstructed time-series is the predicted traffic flow. A novel element of the work is the method whereby precipitation data is used to compliment historical traffic flow data as an additional input to the ACNN forecasting models to develop a weather adaptive traffic prediction algorithm. Accordingly the proposed framework comprises of two parts: One part is a Dry model where traffic flow is predicted using a stationary neuro-wavelet algorithm. The other part is a Wet model which predicts traffic flow utilizing both traffic flow and rainfall information. The Wet model is activated if rainfall is expected in the forthcoming hour, based on local weather forecasts. The following two subsections describe the Dry and Wet forecasting

models.

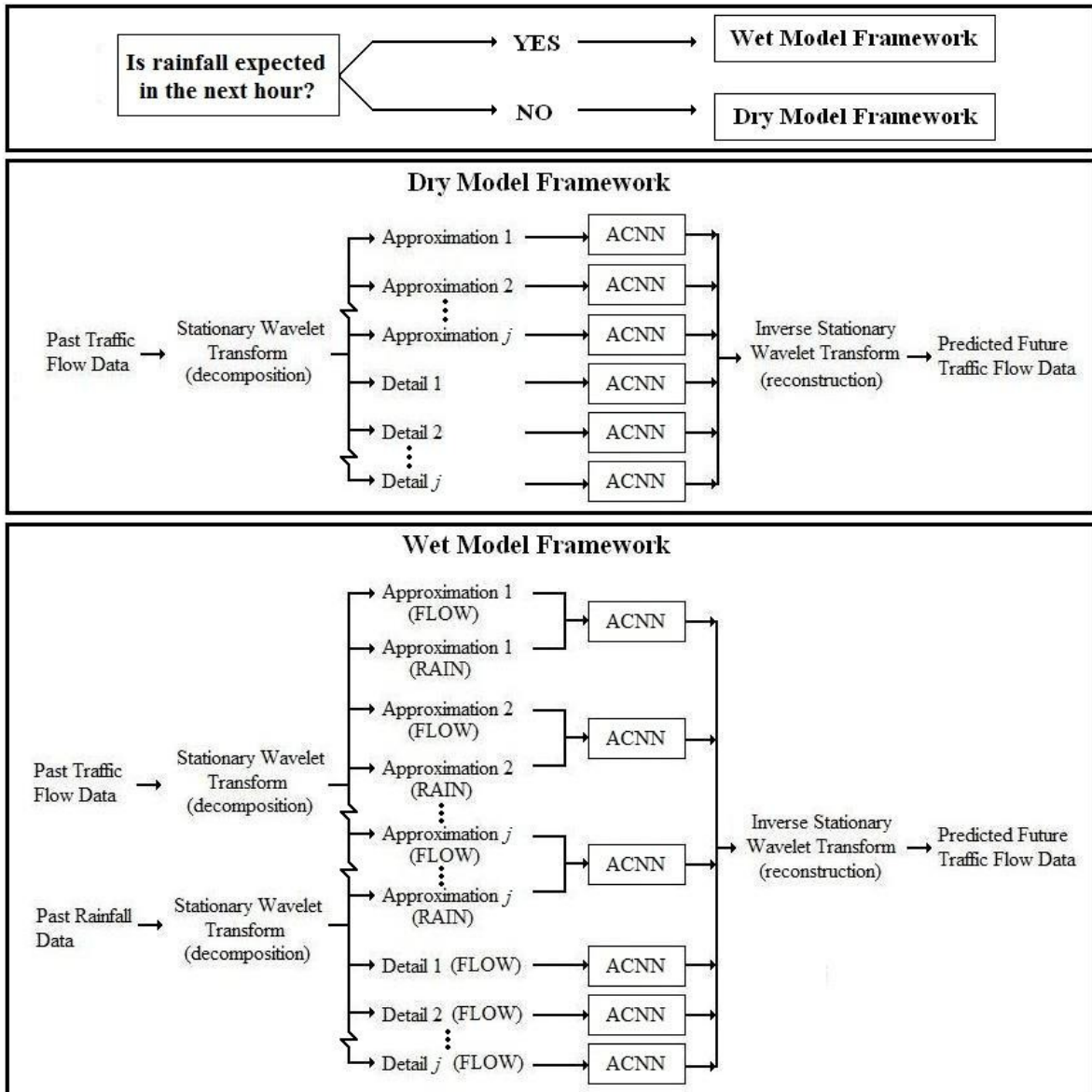

Figure 2 - Stationary Neuro-Wavelet Prediction Framework

Dry Model

The Dry forecasting model predicts traffic flow in near future using current and recent past observations of the same. The first step of the procedure is to decompose traffic flow data using SWT, to an optimized level, j . The approximation and detail components at all levels of decomposition are then forecasted with individual ACNN models, as seen in Fig. 2. These separately forecasted components are then reconstructed using ISWT. The recombination of the separate approximation and detail elements in this way produces a final forecasted time-series, of the same order as the original hourly traffic flow time-series input to the model.

Wet Model

The Wet forecasting model follows the same basic idea as in the Dry model. However, it is unique in incorporating the rainfall data to augment the historical traffic flow data as an extraneous variable for predicting future traffic flow in wet conditions. The current and time-lagged correlation between traffic flow and precipitation time-series can be assumed as an indicator of how much traffic flow is affected by rainfall. This relationship can exist at different frequency levels and by exploiting the multiresolution framework of SWT, the correlation between the two aforementioned time-series has been calculated for the original time-series datasets as well as at different levels of approximation and detail components. The component series showing maximum correlation between traffic and rainfall data have been used as input to the ACNN structure. In most cases, it has been observed that the approximation coefficients of obtained by decomposing the traffic flow and rainfall time-series show the maximum correlation. Therefore in the Wet model as described Fig. 2, the approximation coefficients for both rainfall and traffic flow data are presented as input to the ACNN structure at each level of decomposition, for illustrative purposes. The ACNN algorithms in Wet model are multivariate models, including both rainfall and traffic flow as input, and producing future traffic flow levels as output.

EVALUATION OF NEURO-WAVELET MODEL

Data

The prediction methodology described in the previous section is evaluated using real-time traffic flow data from urban arterials along with hourly precipitation data in Dublin, Ireland. In the following subsections the description of the modeled traffic flow data, rainfall data and the model fitting procedure are described. The data modeled using the proposed prediction methodology is obtained from the Sydney Co-ordinated Adaptive Traffic System (SCATS) database in the Traffic Control Centre of Dublin City Council. The SCATS database constitutes of traffic condition related information from all the major urban arterials in Dublin city-center and the surrounding suburbs. SCATS datasets contain traffic volumes aggregated over every 15 minutes in every lane of a given junction. For this paper, hourly traffic data from January 2009 were collected from two SCATS sites, TCS 106 and TCS 125, as seen in Fig. 3.



Figure 3 - Location of Data Collection Sites

Both these sites lie to the west of Dublin City Centre. TCS 106 is a 5 phase junction consisting of a T-junction where the Kylemore Road meets the Lucan Road. TCS 125 is a 4 phase crossroads where the Nephin Road intersects the Navan Road. It is expected that both sites will be influenced by commuter traffic, with TCS 106 and TCS 125 being situated close to the two major commuter routes, N4 and N3 respectively, in and out of the city.

It is important to note that the traffic flow observations recorded on a weekday are substantially different to those traffic observations recorded on the weekend. Therefore for ensuring consistency in within-day traffic dynamics, only weekday traffic condition observations are modeled in this paper. Fig. 4 shows typical traffic flow levels for a weekday at each of the two junctions modeled. Typically the values are highest around 08:00 hrs as commuters travel to work during the morning peak period and again at 17:00 hrs during the evening peak period, while the roads are quietest from midnight until approximately 06:00 hrs the next morning. It is also evident from Fig. 4 that TCS 106 encounters heavier traffic than TCS 125. Also, the bimodal nature of the traffic flow at TCS 106 indicates that the junction is more affected by commuter traffic. The traffic flow time-series for TCS 125 does not display such prominent peaks and troughs during expected commuter travel hours. The graph shows that the variation of traffic volume at TCS 125 is more stable, with a fairly consistent flow of traffic from 07:00 hrs to 19:00 hrs.

Weather Adaptive Traffic Prediction using Neuro-Wavelet Models
DUNNE, Stephen, GHOSH, Bidisha

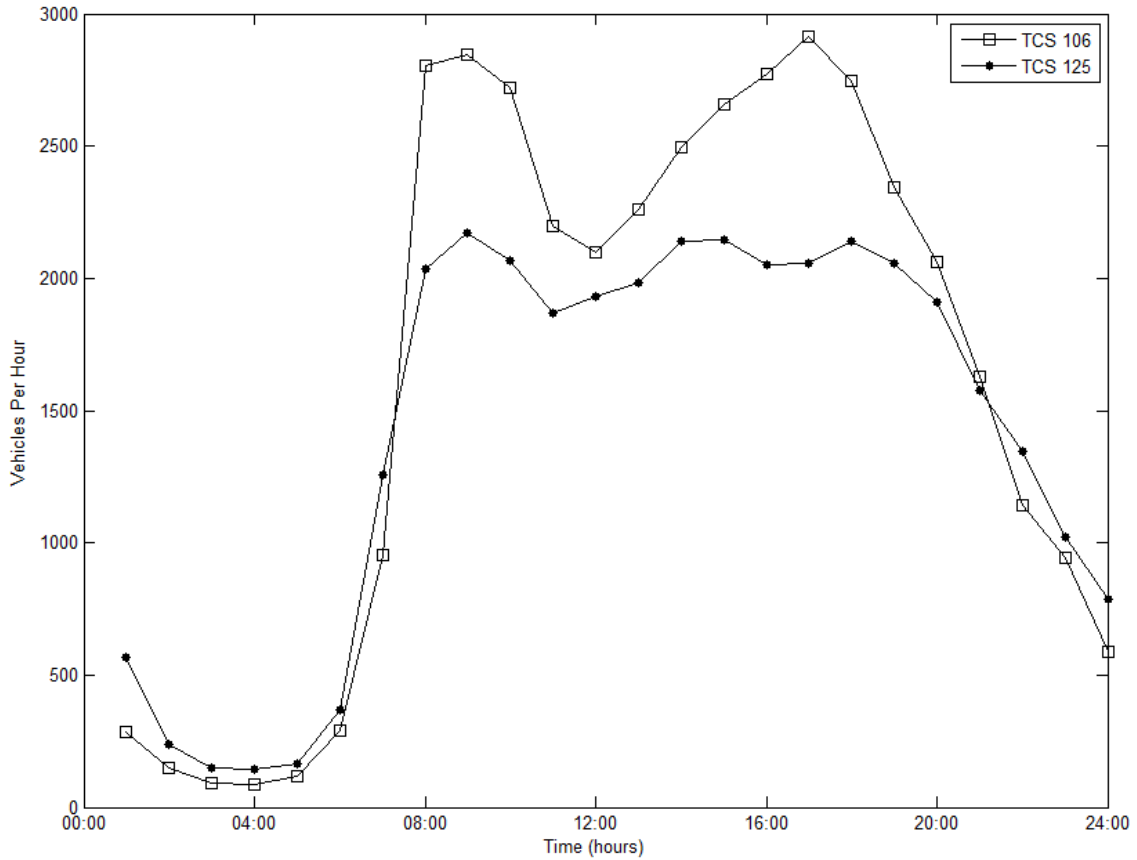

Figure 4 - Typical Weekday Hourly Traffic Flow Data

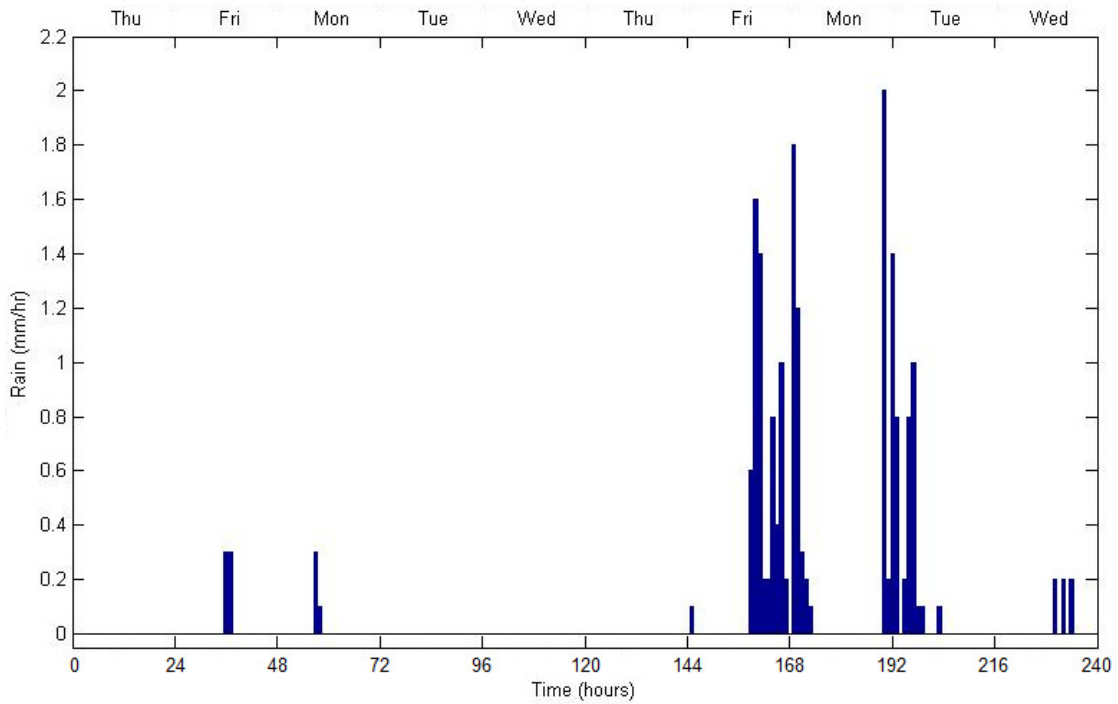

Figure 5 - Barchart of Hourly Rainfall Data for the first 10 Weekdays of 2009

The rainfall data used in this model were collected from the Phoenix Park weather station, as provided by Met Eireann, the Irish National Meteorological Service [37]. The weather station is located in close proximity of the two chosen traffic junctions which ensures that local rainfall events which may affect the traffic flow at the two chosen sites will be reflected in the rainfall records of the chosen weather station (see Fig. 3). Hourly rainfall records were available from the Phoenix Park weather station and hence, traffic flow data at hourly resolution were used for modeling in this paper. The rainfall levels (measured in mm/hr) during the weekdays between 1st and 14th January 2009 are shown in Fig. 5. Generally January and February are the wettest months of the year in Dublin, however at this instance that there were not many rain events during the majority of this time period as can be seen in the figure.

TRAFFIC MODELING USING SWT-ACNN STRUCTURE

Traffic flow time-series data are modeled using an SWT-ACNN structure for future predictions. The framework consists of two parts, as discussed in the methodology, the Dry model and the Wet model.

Dry Model

The proposed neuro-wavelet traffic prediction framework, employed the Dry model to predict traffic flow provided there were no rainfall events existing or expected in the next hour. In this model at the first step, the SWT involving the db3 wavelet basis function [18] was used to decompose the traffic flow time-series into separate approximation and detail coefficients (see Fig. 6). This decomposition was performed multiple times to achieve an optimum level of approximation for representing the within-day traffic dynamics. At each level the approximation coefficients were decomposed using SWT to generate approximation and details coefficients for the next level; the transformation was undecimated and the generated datasets were of the same length as the original traffic flow data. Each different component series generated through SWT, was modeled by an individual ACNN and the output from all ACNN structures were reconstructed using ISWT. In all, 240 observations of hourly traffic flow were used in this model. Eight days were used to train the ACNN (points 1 - 192) while the points from the ninth day (points 193 - 216) were used to predict hourly traffic flow levels on the tenth day (points 217 - 240). The size of the input vectors for the ACNN prediction algorithms was dependent upon the results of the autocorrelation procedure on both hourly traffic flow datasets. Study of the autocorrelation coefficients for TCS 106 showed that 5 points from a 24 hour period were deemed to have an autocorrelation coefficient of sufficient size to be influential in future predictions. Therefore, in the prediction of traffic flow at TCS 106, the training and test datasets made use of these 5 influential points when creating the input vectors for the ACNN. Thus, 5 influential historic hourly traffic flow data points were used to predict a single future hourly

traffic flow value, rather than using the entire 24 points of the day at each iteration of the prediction algorithm.

This procedure was repeated in steps to predict a full 24 hour period. The same methodology was followed for the TCS 125 traffic flow dataset, although only 3 points were deemed influential in this case. In case of rainfall events, the framework switched to a Wet model. The standard ANN model used for comparison in this work used the entire 24 points from a day for prediction. In this way, the SWT-ACNN model is also valuable as a model that reduces computational time e.g. in the case of TCS 125, the standard ANN prediction dataset was 8 times larger than that used in the SWT-ACNN model, thus the SWT-ACNN model computed a prediction in a shorter time.

Wet Model

As discussed in the methodology, traffic flow is affected by weather [25] and hence rainfall data was included in the Wet model framework. Rainfall data time-series were decomposed using SWT in the same way as the traffic flow data. Current and time-lagged correlation coefficients were calculated to determine whether rainfall events and traffic flow were related substantially at different frequencies to improve the forecast accuracy. The correlation coefficients between rainfall data and traffic flow data at junction TCS 106 are shown in Table 1, as an illustrative example.

Table 1: TCS 106 Rainfall Data Correlation Coefficients

	A	B	C
Original Time-Series	0.1114	0.2998	0.2808
Approximation Level 1	0.1199	0.3157	0.3459
Approximation Level 2	0.1316	0.3860	0.3879
Approximation Level 3	0.1404	0.3224	0.2943
Detail Level 1	0.0140	0.0793	0.0492
Detail Level 2	0.0087	0.0341	0.0153
Detail Level 3	0.0889	0.1796	0.2116

Correlation coefficients for the original time-series and their SWT components (approximation and detail coefficients at 3 levels in this case) were all looked at individually to ascertain which components had the highest correlation. The labels A, B and C in Table 1 refer to conditions under which the correlation coefficients were calculated. In condition A, the entire rainfall and traffic flow datasets were used for calculating the correlation coefficients. This condition resulted in the lowest levels of correlation as expected because, for a large proportion of the time, the rainfall data is 0 mm/hr and this skews the relationship between traffic flow and rainfall. Condition B focused on the correlation present only in instances where there is some

level of rainfall in a given hour. As seen in Table 1, this resulted in an improved level of correlation. The results for Condition B in Table 1 along with visual inspection of Fig. 5 vindicate the decision to calculate correlation coefficients at times when rain is present only to negate the effect of large proportion of 0 values in the rainfall dataset. Condition C looked at hours where rain was present along with a single following hour of such time periods. This was to allow for the delayed affect that inclement weather can cause to traffic flow levels and behavior i.e. traffic jams formed under rainy conditions may still be present for a percentage of the following dry hour.

Conditions B and C both produced similar levels of correlation between rainfall and traffic flow at junction TCS 106. An interesting result was that there is a much greater correlation present in the approximation coefficients than the detail coefficients. Based on this behavior, the decision was made to only use the approximation components of the decomposed hourly rainfall data as part of the inputs in the Wet model framework. It was also decided that the when rainfall was expected in the forthcoming hour, the Wet model would be activated for both the forthcoming hour and the hour after that to allow for the time-lagged effect of rainfall on within-day traffic flow dynamics. Also, in the Wet model, the input vector sizes for the individual ACNN were twice the size as the respective Dry model input vectors i.e. where 3 hourly traffic flow data points were used to predict 1 future data point at TCS 125 in the Dry model, 6 points (3 hourly traffic flow and 3 hourly rainfall) were used for the same in the Wet model case

PREDICTIONS & COMPARISONS

The SWT-ACNN model has been used to predict the traffic volume on Wednesday, January 14th 2009 for junctions TCS106 and TCS 125. The forecasts and the observed traffic volumes are plotted in Fig. 6a and 7b. To illustrate the efficiency of SWT-ACNN structure, a standard ANN algorithm, comparable to the fundamental FFBPNN structure used in the ACNN model, has been used to predict traffic volume on the same day over a 24 hour period. The shaded boxes in Fig. 6a and 7b show periods of rainfall (from 14:00 hrs to 19:00 hrs) where the Wet model framework took over from the Dry model framework, as discussed in the methodology. It is important to note here that the rainfall in this period was actually intermittent, as seen by close inspection of Fig. 5. Rainfall events occurred at 14:00 hrs, 16:00 hrs and 18:00 hrs but the hours in between were also subject to the Wet model prediction algorithm in order to address the time-lagged effect of precipitation on traffic flow i.e. the Wet model activates for hours t and $t+1$ when rain is expected at hour t . It is immediately visible from the graph that the wavelet model outperforms the non-wavelet model significantly. Table 2 presents the mean absolute percentage error (MAPE) and root mean squared error (RMSE) from the predictions carried out at TCS 106 and TCS 125.

Weather Adaptive Traffic Prediction using Neuro-Wavelet Models
DUNNE, Stephen, GHOSH, Bidisha

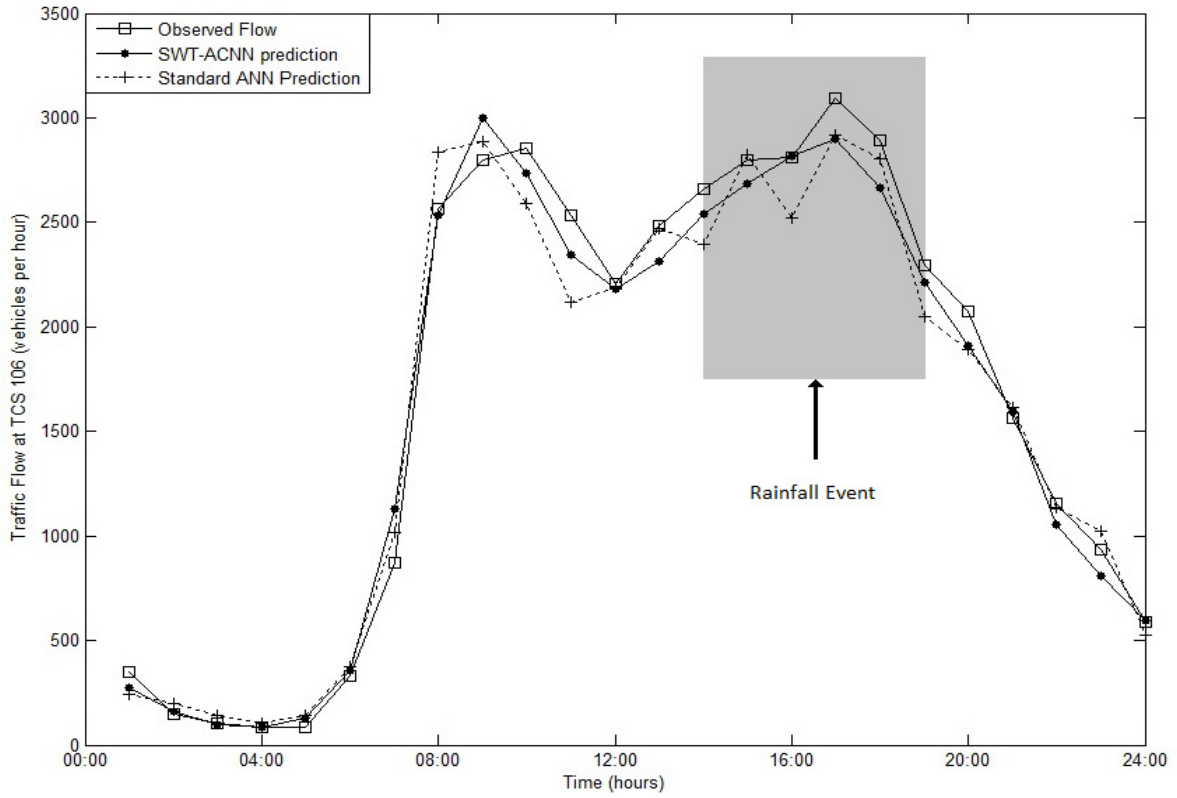

(a)

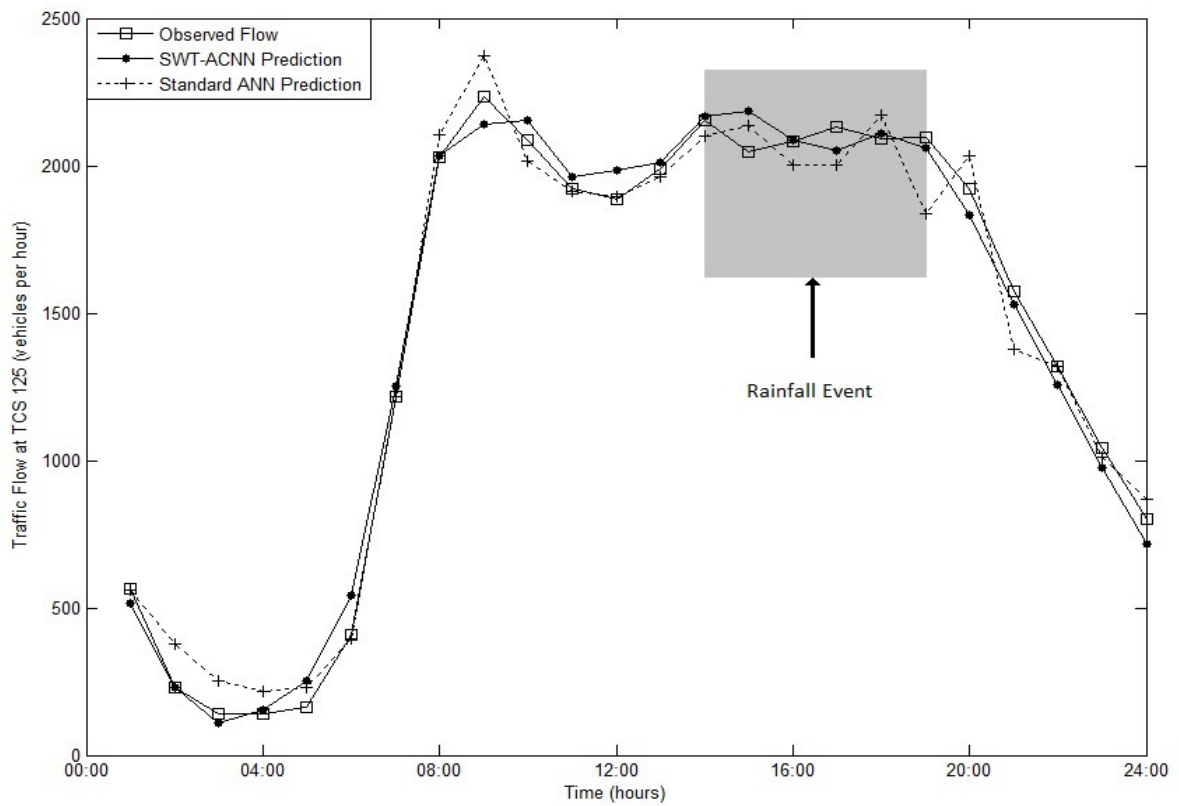

(b)

Figure 6 - (a) TCS 106 Prediction Results & (b) TCS 125 Prediction Results

Table 2: Prediction Accuracy - MAPE and RMSE

		TCS 106	TCS 125
	Mean (vehicles/hour)	1664.5000	1446.5000
	Standard Deviation	1087.8000	745.0892
SWT-ACNN	MAPE	9.0938	8.0082
	RMSE	125.4183	67.2349
ANN	MAPE	14.1061	13.3406
	RMSE	165.8897	100.0232

The values in Tables 2 emphasize the importance of using a multi-resolution framework in incorporating the effect of rainfall in traffic prediction, with the SWT-ACNN more accurate at both TCS 106 and TCS 125, based on the MAPE and RMSE values. As an illustrative example of the effectiveness of the Wet model in predicting traffic flow, Table 3 presents the MAPE for the neuro-wavelet prediction model during dry and wet times at junctions TCS 106 and TCS 125.

Table 3: Wet and Dry Condition MAPE

TCS 106 SWT-ACNN Model		
Overall MAPE (24 points)	Dry Time MAPE (18 points)	Wet Time MAPE (6 points)
9.0938	10.6463	4.4362
TCS 106 Standard ANN Model		
Overall MAPE (24 points)	Dry Time MAPE (18 points)	Wet Time MAPE (6 points)
14.1061	16.5664	6.7254
TCS 125 SWT-ACNN Model		
Overall MAPE (24 points)	Dry Time MAPE (18 points)	Wet Time MAPE (6 points)
8.0082	9.9116	2.2979
TCS 125 Standard ANN Model		
Overall MAPE (24 points)	Dry Time MAPE (18 points)	Wet Time MAPE (6 points)
13.3406	15.9555	5.4958

The table is based on the predictions shown in Fig. 6a and 7b, where a rainfall event occurs from 14:00 hrs to 19:00 hrs. Hence, for this time period, the Wet model is enabled as the chosen prediction methodology. The findings in Table 3 emphasize how effective it can be to include rainfall as an input to the neuro-wavelet model.

CONCLUSION

Rainfall effects travel dynamics in urban transport networks in a complex manner and causes congestion and often an increased frequency of accidents on the roads. A neuro-wavelet prediction algorithm has been proposed in the paper to forecast hourly traffic flow taking into account the effect of precipitation. The neuro-wavelet structure utilizes a multiresolution wavelet analysis framework to address the fact that rain can affect traffic flow dynamics at different resolution levels. To retain the time-invariance of the original time-series datasets an undecimated form of WT (SWT) has been used in this purpose. This model taking rain into account is a novel application of SWT in the field of traffic prediction.

The algorithm toggles between a Dry and a Wet model depending on whether rainfall is expected in the forthcoming hour. The algorithm was evaluated using real-time hourly traffic volume and precipitation observations. The prediction accuracy of the Wet model is superior to the Dry model and the standard ANN model during rainfall periods. This emphasizes that rainfall affects traffic volume and the inclusion of rainfall as a model input improves the prediction accuracy during rainfall events. The algorithm also outperformed the conventional ANN algorithms in dry situations (where traffic flow data alone were used as model input). This confirms that the proposed algorithm is flexible and can be applied to situations where and when rainfall data is not available. For future research in this area, it will be important to investigate the performance of this algorithm using higher resolution traffic and rainfall time-series datasets.

References

- Cheslow, M. (1992). "An Initial Evaluation of Alternative Intelligent Vehicle Highway Systems Architectures." MITRE Report
- Head, L. K. (1995). "Event-based short-term traffic flow prediction model." Transportation Research Board, 1510, pp. 45–52.
- Smith, B.L. and Demetsky, M.J. (1997). "Traffic flow forecasting: Comparison of modelling approaches." J. Trans. Eng., ASCE, vol. 123, no. 4, pp. 261-266.
- Kirby, H., Dougherty, M., and Watson, S. (1997). "Should we use neural networks or statistical models for short term motorway forecasting?" International Journal of Forecasting 13, 45–50.
- Dougherty, M.S. and Cobbett, M.R. (1997). "Short-term inter-urban traffic forecasts using neural networks." International Journal of Forecasting, 13, pp. 21–31.
- Zhang, H. M. (2000). "Recursive prediction of traffic conditions with neural networks." Journal of Transportation Engineering, 126(6), pp. 472–481.
- Hamad, K., Shourijeh, M.T., Lee, E. & Faghri, A. (2009). "Near-term travel speed prediction utilizing Hilbert-Huang transform." Computer-Aided Civil and Infrastructure Engineering, 24, 551–76.

Weather Adaptive Traffic Prediction using Neuro-Wavelet Models

DUNNE, Stephen, GHOSH, Bidisha

- Lingras, P. and Mountford, P. (2001). "Time delay neural networks designed using genetic algorithms for short-term inter-city traffic forecasting." IEA/AIE 2001, LNAI 2070, pp. 290–299.
- Lint, J., Hoogendoorn, S. & Zuylen, H. (2002). "Freeway travel time prediction with State-Space Neural Networks: modeling state-space dynamics with recurrent neural networks" Transportation Research Record 1811, Transportation Research Board, Washington D.C., 30–39.
- Abdulhai, B., Porwal, H., & Recker, W. (2002). "Short-term traffic flow prediction using neuron-genetic algorithms" ITS Journal, Taylor and Francis, London, 3–41.
- Vlahogianni, E.I., Karlaftis, M.G. and Golias, J.C. (2007). "Spatio-temporal short-term urban traffic volume forecasting using genetically optimized modular networks." Computer-Aided Civil and Infrastructure Engineering, v 22, n 5, p 317-325, July 2007.
- Park, D., Rilett, L.R. and Han, G. (1999). "Spectral basis neural networks for real-time travel time forecasting" Journal of Transportation Engineering, 125(6), pp. 515–523.
- Stathopoulos, A., Dimitriou, L., and Tsekeris, T. (2008). "Fuzzy modeling approach for combined forecasting of urban traffic flow." Computer-aided Civil and Infrastructure Engineering 23, 521–535.
- Zhang, X.-L. and He, G.-G. (2007). "Forecasting Approach for Short-term traffic Flow based on Principle Component Analysis and Combined Neural Network." Systems Engineering - Theory & Practice, Volume 27, Issue 8, August 2007, Pages 167-171
- Vlahogianni, E.I., Karlaftis, M.G., Golias, J.C. and Kourbelis, N.D. (2006). "Pattern-Based Short-Term Urban Traffic Predictor," Intelligent Transportation Systems Conference, 2006. ITSC '06. IEEE , vol., no., pp.389-393, 17-20 Sept. 2006
- Karlaftis, M.G. and Vlahogianni, E.I. (2011). "Statistical methods versus neural networks in transportation research: Differences, similarities and some insights." Transportation Research Part C: Emerging Technologies, 19 (3), pp. 387-399.
- Mallat, S. G. (1989) A theory for multiresolution signal decomposition: the wavelet representation, IEEE Transactions on Pattern Analysis and Machine Intelligence, 11, No. 7, 674-693.
- Daubechies, I. (1992). "Ten Lectures on Wavelets", CBMS-NSF Regional Conference Series in Applied Mathematics, SIAM: Philadelphia.
- Samant, A. & Adeli, H. (2001). "Enhancing Neural Network Traffic Incident-Detection Algorithms Using Wavelets" Computer-Aided Civil and Infrastructure Engineering 16 (2001) 239–245
- Karim, A. and Adeli, H. (2003) "Fast Automatic Incident Detection on Urban and Rural Freeways Using Wavelet Energy Algorithm" Journal of Transportation Engineering, Vol. 129, No. 1, January 1, 2003.
- Liang, X.R. and Wei, Y.X. (2007) "Freeway Traffic Flow Modeling Based on Recurrent Neural Network and Wavelet Transform" International Conference on Transportation Engineering 2007 (ICTE 2007)
- Zhang, B.-L., Coggins, R., Anwar Jabri, M., Dersch, D. and Flower, B. (2001). "Multiresolution Forecasting for Futures Trading Using Wavelet Decompositions" IEEE Transactions On Neural Networks, Vol. 12, No. 4, July 2001

Weather Adaptive Traffic Prediction using Neuro-Wavelet Models

DUNNE, Stephen, GHOSH, Bidisha

- Liu, F.-Y. (2009) "Forecasting Renminbi Exchange Rates Based on Autocorrelation Shell Representation and Neural Networks" 2009 International Association of Computer Science and Information Technology - Spring Conference
- Boto-Giralda, D., Diaz-Pernas, F.J., Gonzalez-Ortega, D., Diez-Higuera, J.F., Anton-Rodriguez, M., Martinez-Zarzuela, M. and Torre-Diez, I. (2010). "Wavelet-Based Denoising for Traffic Volume Time Series Forecasting with Self-Organizing Neural Networks" *Computer-Aided Civil and Infrastructure Engineering* 25, 530–545
- Chung, E., Ohtani, O., Warita, H., Kuwahara, M. and Morita, H. (2005). "Effect of Rain on Travel Demand and Traffic Accidents" *Proceedings of the 8th International IEEE Conference on Intelligent Transportation Systems Vienna, Austria, September 13-16, 2005*
- Maze, T., Agarwal, M. and Souleyrette, R. (2005). "Impact of Weather on Urban Freeway Traffic Flow Characteristics and Facility Capacity" *Integration of Road Weather Information with Traffic Data*
- Vlahogianni, E.I., Karlaftis, M.G. (2012) "Comparing traffic flow time-series under fine and adverse weather conditions using recurrence-based complexity measures" (2012) *Nonlinear Dynamics*, pp.1-15.
- Wang, J., Wang, H., Wu, W. and Yang, X. (2010). "Impact of weather on morning peak congestion" 2010 *International Conference on Optoelectronics and Image Processing*
- Tsirigotis, L., Vlahogianni, E.I., Karlaftis, M.G. (2012). Does Information on Weather Affect the Performance of Short-Term Traffic Forecasting Models? (2012) *International Journal of Intelligent Transportation Systems Research*, 10 (1), pp. 1-10.
- Nason, G., Silverman, B. (1995). "The stationary wavelet transform and some statistical applications" *Springer Lecture Notes in Statistics*, 103, 281–300
- Haykin, S. (1994) *NN: A Comprehensive Foundation* (New York, NY: Macmillan).
- Bishop, Ch.M. (1995). *Neural Networks for Pattern Recognition*. Oxford University Press, ISBN:0-19-853864-2
- Principe, J.C., Euliano, N.R., Lefebvre, C.W. (2000). *Neural and Adaptive Systems: Fundamentals Through Simulations*. John Wiley & Sons Inc.
- Dunne, S. and Ghosh, B. (2010). "Optimal Data Aggregation Interval for Traffic Flow Prediction in Urban Arterials: A Neural Network Approach." *IMA 5th International Conference on Mathematics in Transport*, University College London.
- Levenberg, K (1944). "A method for the solution of certain problems in least squares," *Quart. Appl. Math.*, 1944, Vol. 2, pp. 164–168.
- Marquardt, D. (1963). "An algorithm for least-squares estimation of nonlinear parameters." *SIAM J. Appl. Math.*, 1963, Vol. 11, pp. 431–441.
- Met Eireann website: <http://www.met.ie>