

PUBLIC UTILITY FLEET MANAGEMENT: ACTIVITY BASED COSTING METHOD APPLICATION

Aleksandar Manojlović, Faculty of Transport and Traffic Engineering, University of Belgrade, Serbia, a.manojlovic@sf.bg.ac.rs

Olivera Medar, Faculty of Transport and Traffic Engineering, University of Belgrade, Serbia, o.medar@sf.bg.ac.rs

Dragana Drenovac, Faculty of Transport and Traffic Engineering, University of Belgrade, Serbia, d.drenovac@sf.bg.ac.rs

Snežana Filipović, Faculty of Transport and Traffic Engineering, University of Belgrade, Serbia, s.filipovic@sf.bg.ac.rs

ABSTRACT

Public companies' fleets are often composed of several hundreds of vehicles of different categories. Within the complex organization structure, the fleets are providing support for the company's core activities. The vehicles are used by company's departments for different purposes, i.e. such departments represent users of Fleet department's vehicles and services. The vehicles of the same categories used by different users significantly vary in matter of travelled distances, hours in operation and costs. Activities' costs give impression of the effectiveness of fleet resource usage and to what extent important activities contribute to the services' costs. Those information represent a key issue in the decision-making process on eventual restructuring of the Fleet Department or while outsourcing some of the activities..

Keywords: fleet management, large vehicle fleet, activity based costing, cost efficiency

INTRODUCTION

Considering transport costs' structure in public utility companies, determining the amount of the overhead is the first emerging problem, followed by their allocation to specific services and users. The major part of transport overhead is being referred to as costs of the Fleet Department (FD). Company structure is complex: many departments, located on several sites in the wide area, where different sort of activities are performed: management, maintenance, transport. For those activities the FD engages facilities, utilities, and services of other departments. In such a situation by means of the traditional cost accounting, it is not

possible to identify the amount of the FD overhead, while the detailed data collection on transport costs requires additional efforts and investments.

Developed procedure for transport cost allocation within a public company and for setting a rate regarding the transport service's cost coverage is presented. Applying Activity Based Costing gives more precisely and trustworthy basis for the transport cost allocation regarding the usage of vehicles. Determination of the transport direct costs and overhead amounts, and overhead allocation to services, performed by the FD, as well to vehicle groups and to specific user, by using the Activity Based Costing model are first activities of the procedure. Using the costs data obtained from described activities we could obtain information on the rates of services realized by the FD, vehicle usage rate upon vehicle-kilometre, and amounts charged to the departments. Creation of different rates is allowed for the vehicle usage upon categories and different users. Determined FD activity cost levels are valuable information for decision making about which services and in what extents should be preserved within the company and which ones will be outsourced.

Previously defined procedure has been illustrated through a case study of public utility company in Belgrade, with a fleet of more than 400 vehicles classified in ten groups, within nine departments. Charged costs of vehicle-kilometres for certain users are differing for as much as 50%, influencing the size of the fleet.

FLEET COSTS

The knowledge of the level of realized costs and cost efficiency parameters, as unit costs per kilometre travelled, realized journey and hours in operation, enables operation results analysis and represents a basis to for comparisons to other vehicle fleets. To provide a basis for cost management and monitoring, as well as to assure a referential foundation for measuring the cost control effectiveness, it is indispensable to standardize vehicle and fleet costs (Lauria and Owen, 2004). The Figure 1 show particular cost category, activities and cost objects of the transport subsystem.

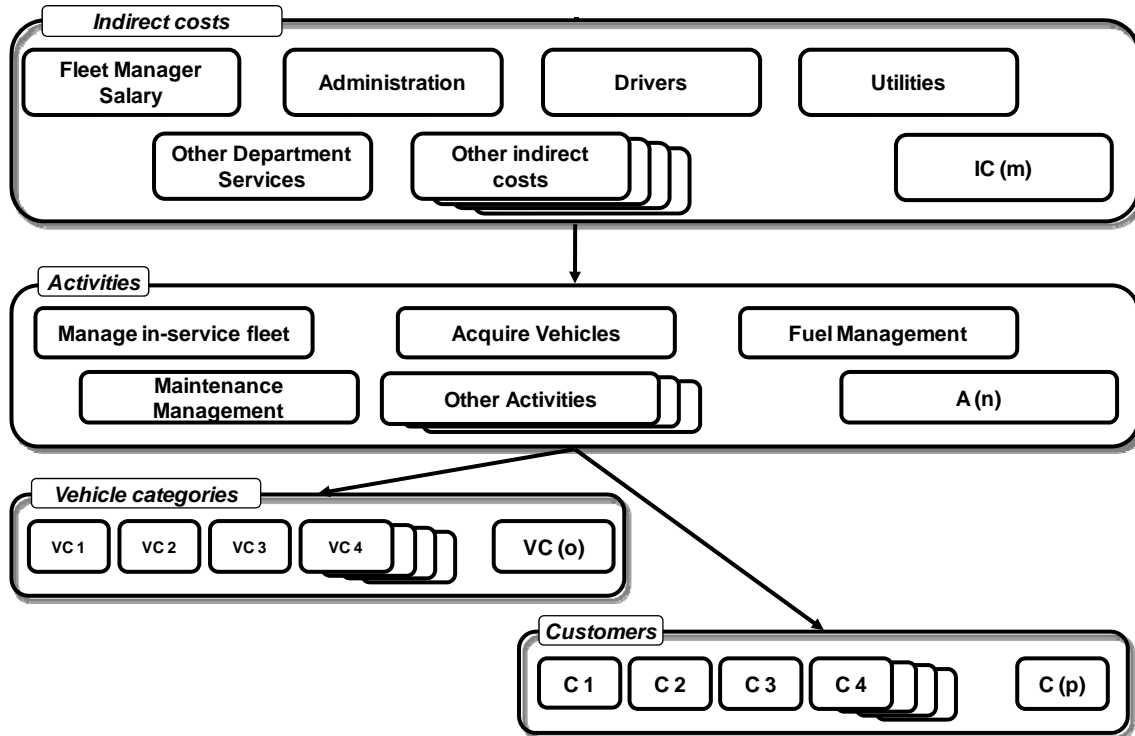

Figure 1 – Cost category, activities and cost objects

The procedure for transport overhead allocation within a public company and for setting the rate regarding the transport service's cost coverage, more precisely regarding the usage of vehicles established on the Activity Based Costing consists of several steps. Determination of the the transport direct costs and overhead is the first step (Roztockı et al., 1999). Afterwards overheads are allocated to the FD services, to the group of vehicles and to users by using the Activity Based Costing model (Figure 2).

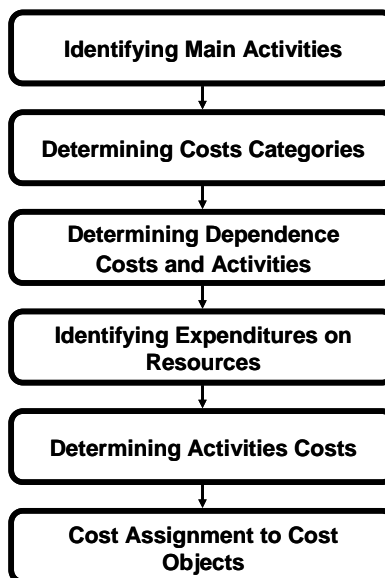

Figure 2 – Procedure for transport overhead allocation

Based on obtained costs data, the information on services rates, vehicle usage rate upon vehicle-kilometre and tehe amounts charged to the departments, could also be achieved. The creation of different rates is allowed for the vehicle usage upon categories and different users. Determined Fleet department activity costs allows the decision makers to decide which services and in what extents will be preserved within the company and which ones will be outsourced.

CASE STUDY

Previously defined procedure has been implemented in one public utility company in Belgrade, whose fleet is composed of 409 vehicles sorted in ten categories within nine departments.

The transport process as a supporting process to the core company process is decentralized in such a way that it is integrated into sectors', functions' and administration's – vehicle users where the core processes are performed. On the other hand, there is a central Transport organization unit (FD) with competencies in particular segments of the transport process. Vehicles are designated for fulfillment of particular users' needs within a sector, and any assistance is effected neither between vehicles belong to the same sector nor among specific sectors, regarding vehicle loan and/or exchange.

Fleet Department activities are: administrative activities, analysis of customers' activities, acquisition and re-market of vehicles, vehicle condition verification and certification, fleet maintenance management, fuel management and transport. Cost categories and cost drivers are presented in Table 1.

Table 1 – Cost categories and cost drivers

Cost categories	€	Cost driver
Fleet manager salary	66.324	Time (h)
Maintenance manager salary	24.509	Time (h)
Driver salary	42.300	Time (h)
Mechanics salary	93.323	Time (h)
Utilities	114.286	Space (m ²)
Office costs	15.662	Level of use of office resources (%)
Other department services	76.314	Level of use of other department services (%)
Driver cost of own vehicles	6.830	Distance (km)
Driver costs of special vehicles	15.360	Distance (km)
	Σ454.908	

Figure 3 presents the results of cost tracing and cost allocation to the the cost object (vehicles categories and fleet customers) and Figure 4 shows fleet costs and activities' costs.

Public Utility Fleet Management: Activity Based Costing Method Application
 MANOJLOVIĆ, Aleksandar; MEDAR, Olivera; DRENOVAC, Dragana; FILIPOVIĆ, Snežana

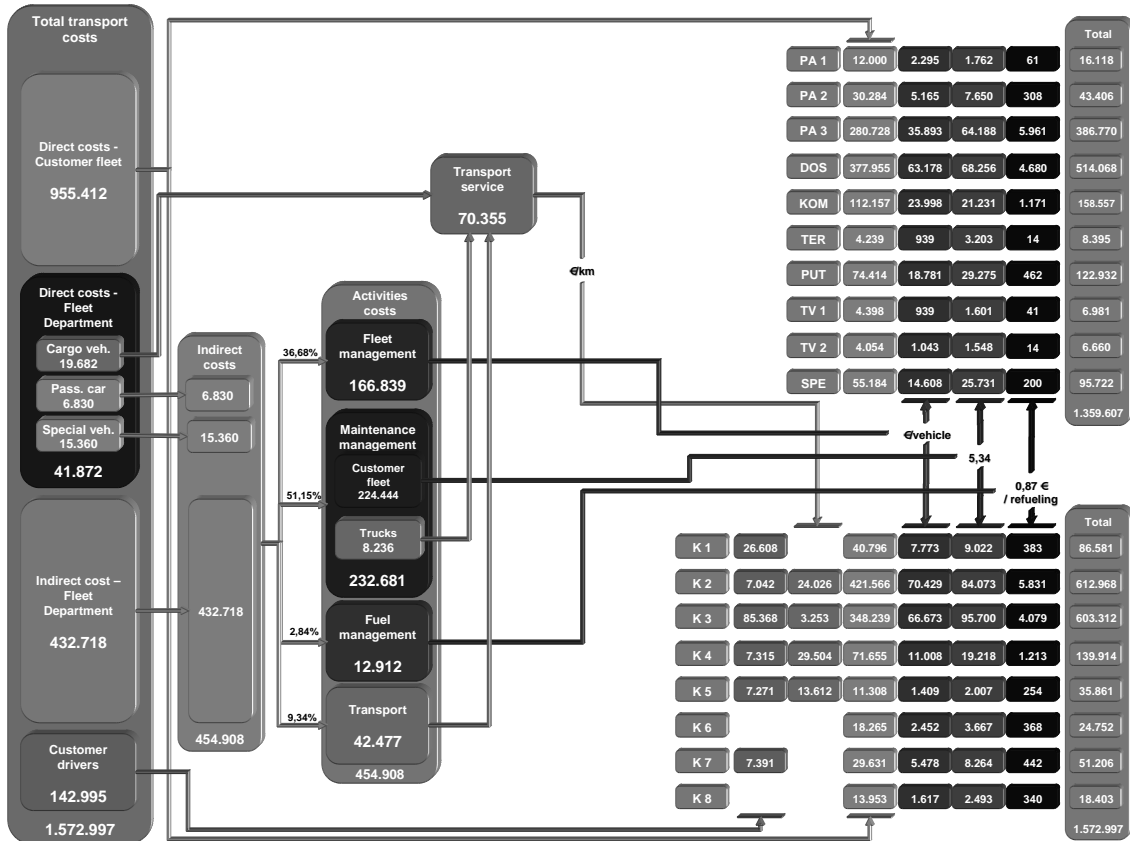

Figure 3 – Cost tracing and cost allocation to the cost objects

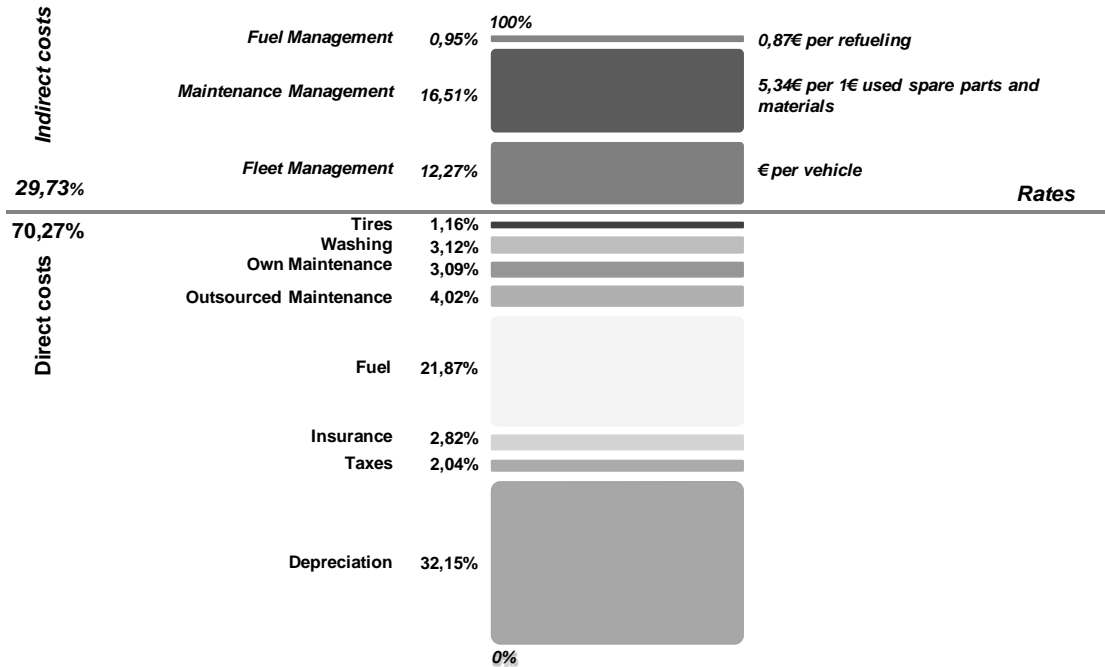

Figure 4 – Fleet costs with activities' costs

The cost structure and values of total and unit costs with included activities' costs, sorted by vehicle groups (Figure 5), are well-suited for recognition of the possible fleet operation enhancements in the phase of vehicle ownership model definition and for consideration of the subcontractors' engagement and choice. Besides, this is an important element in the decision-making regarding fleet dimension and also provides a basis for the chargeback system establishment.

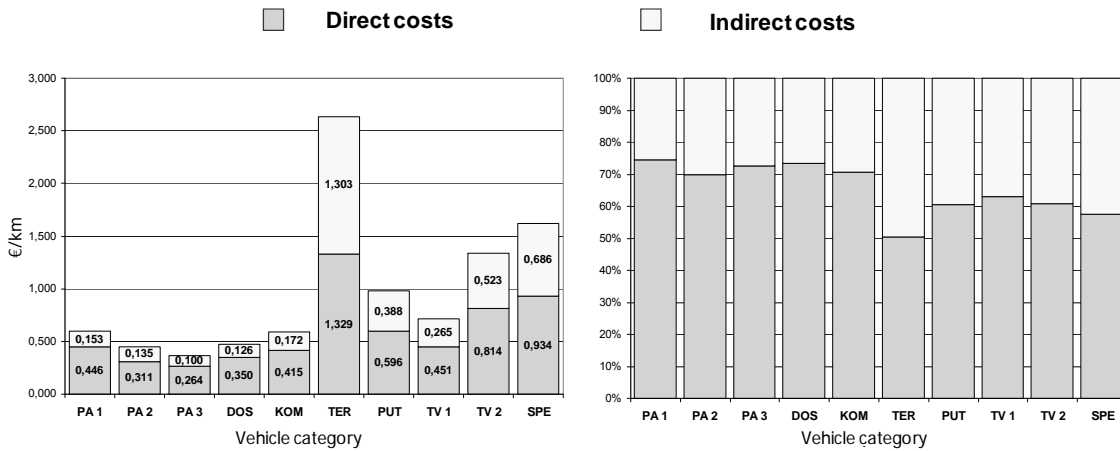

Figure 5 – Total and unit cost

Different vehicle groups "spend" activities in different amounts. The value and structure of annual indirect costs per vehicle is shown in Figure 6. In relation to the origination moment, the activities' costs are composed of a fixed part, costs of activity "Fleet Management", and variable part, costs of activity "Maintenance Management" and "Fuel Management".

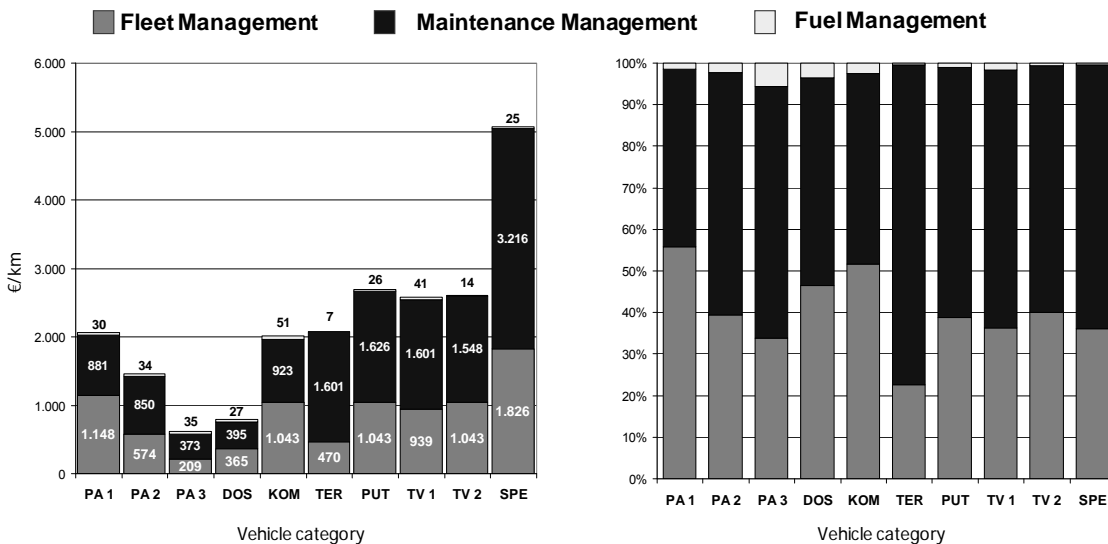

Figure 6 – Cost of main activities

Activities' costs give an impression about effectiveness of the fleet resource usage and to what extent important activities contribute to the services' costs.

CONCLUSIONS

This paper presents the procedure for transport overhead allocation within a public company and for setting the rate regarding the transport service's cost coverage, more precisely regarding the usage of vehicles established on the Activity Based Costing. Recommended procedure ensures a high-quality basis for the decision making regarding fleet utilization strategies, especially in matter of public companies' fleets. The cost structure with incorporated activities' costs is suitable for the recognition of possible enhancements and for the decision-making in matter of vehicle fleet dimensioning. Information on activities' costs represents a key issue in the decision-making process about eventual restructuring of the Fleet Department or while outsourcing some of the activities.

REFERENCES

- Lauria, P., and Owen. R. (2004). *Managing Managed Competition*. NAFA's Fleet Management Institute
- Roztock, N., Valenzuela, J., Porter, J., Monk, R. and K. Needy (1999). *A Procedure for Smooth Implementation of Activity Based Costing in Small Companies*, Proceedings from the ASEM National Conference, American Society for Engineering Management