

MODELLING THE FEEDBACKS BETWEEN TRADE AND TRANSPORT

Wolfgang Schade^a, Michael Krail

Institute for Economic Policy Research (IWW), University of Karlsruhe (TH), Kollegium
am Schloss, Bau IV, 76128 Karlsruhe, Germany

wolfgang.schade@iww.uni-karlsruhe.de, krail@iww.uni-karlsruhe.de

^aCorresponding Author

Abstract

This paper presents an alternative to new economic geography and its general equilibrium approach to bring forward modelling and analysis of trade and transport interactions. It agrees with the necessity of modelling fully-fledged policies - linked with "general" in the notion of general equilibrium – instead of partial policies. In contrast to new economic geography it suggests to apply dynamic or evolutionary models since trade and transport relationships incorporate a strong time dependency as interactions between trade and transport unfold over years and behaviour in year t depends on trading or transport decisions taken during a number of previous years. Following this concept the System Dynamics model ASTRA is applied to shed light on the longer-term reactions of trade and transport due to selected European transport policies. Results of analyses reveal different mechanisms that in parallel to the direct linkage between trade and transport decide if countries gain or lose by a specific transport policy.

Keywords: Trade, transport, new economic geography, dynamics, integrated assessment, fully-fledged policies

Topic Area: D2 Freight Transport Demand Modelling

1 Introduction

The trade and transport model presented in this paper accounts for part of a larger dynamic integrated economy – transport – environment assessment model. That means neither does it follow the general equilibrium approach suggested by new economic geography e.g. by VENABLES/GASIOREK (1999), FUJITA/KRUGMAN/VENABLES (1999) or STEININGER (2001) nor does it apply the Iceberg-approach for considering transport cost as introduced by SAMUELSON (1954) and followed by many others. Instead, it constitutes part of a dynamic dis-equilibrium modelling framework in which transport cost and transport time affecting trade relationships depend on the individual characteristic of the transport system linking the trading partners, which are represented by the current EU15 member states.

In the 50th anniversary issue of Papers in Regional Science it is reflected by leading scholars of the field how regional analysis might develop in the future (WALDORF 2003). BATTY discussing WILSON's contributions (1970) concludes that introducing dynamics and the time component into regional science models would be the way forward. Similar, CHATTERJI discussing the contribution of FUJITA/KRUGMAN/VENABLES (1999) argues that their approach would lack the "*transfers to dynamic formulations*" and the replacement of the Iceberg-transport-cost model by detailed transport cost considerations. In that sense, the approach presented in this paper fulfils the requirements formulated in the WALDORF paper. On the other hand, it differs from these suggestions as it does not apply general equilibrium modelling at all, but System Dynamics methodology that could be

characterised as dynamic time-path modelling. However, a major commitment of the approach is to analyse fully-fledged policies instead of partial ones.

Baseline for modelling trade and transport interactions is given by that there exists reciprocity between trade and transport that establishes feedback loops between the two. Undoubtedly trade influences transport as in general more trade led to more international transport over the past. And on the other hand transport affects trade by reducing barriers between trading partners e.g. by decreasing travel times and providing more opportunities to access locations and to find new trading partners. Again this affects international transport. However, there are further feedback loops between the two that influence national transport, also. More trade tends to increase gross domestic product (GDP) of the exporting country. Since so far no decoupling between GDP growth and transport growth has been observed the growth of GDP is always going along with national transport growth. That is national transport experiences also impacts from international trade.

Trade and Transport, acting as briefly explained above, account for two out of eight modules of the system dynamics model ASTRA (=Assessment of Transport Strategies) (SCHADE 2004). ASTRA is originally developed in several European research projects to analyse the long-term impacts of transport and other policies for the fifteen current EU member states (e.g. SCHADE/FIORELLO/MARTINO 2002). ASTRA comprises eight modules: population (POP), macro-economy (MAC), regional economy (REM), foreign trade (FOT), vehicle fleet (VFT), transport (TRA), environment (ENV) and welfare measurement (WEM). Between these eight modules manifold interactions are implemented of which the feedback loops between trade and transport are only some of them. (see Figure 1).

The ASTRA population module generates the demographic framework for the MAC and the REM modules based on 1-year age cohorts. The aim of the MAC module is to provide an aggregate macroeconomic environment in which the FOT, REM, TRA, VFT and ENV modules are embedded. The MAC incorporates an endogenous growth component that is able to generate growth effects of policies and a sectoral interchange component that considers impacts of sectoral interweavement between the 25 economic sectors of each of the national economies. POP, MAC and FOT integrate the macroscopic information on national and continental level influences into the model while other modules operate on a micro- or meso-level. This has the advantage that feedback loops, which commence on the micro- or meso-level in one of the modules (e.g. transport expenditures for one mode in one distance band in the TRA) and then end up with an effect on the national level (e.g. changes in sectoral consumption and gross-value-added), can influence the originating module such that the feedback loop is closed e.g. in this case by the integration of the MAC module. Closing the feedback loop then implies to establish either macro-micro-bridges (e.g. from GDP and sectoral output to goods flows) or vice versa micro-macro-bridges (e.g. from transport investments into vehicle fleets to overall investments).

There are various well-known theoretical concepts integrated in the model. E.g. in the MAC neo-classical production functions are implemented to calculate the potential output of the national economies. On the other hand, the production functions include endogenous total factor productivity that is borrowed from endogenous growth theory. The calculation of investments follows to some extent Keynesian theory as investments depend on consumption and, as an additional element, on exports. The core of transport modelling is based on the classical 4-stage transport model applying logit-functions depending on generalised costs e.g. to calculate the modal-split (ORTUZAR/WILLUMSEN 1998).

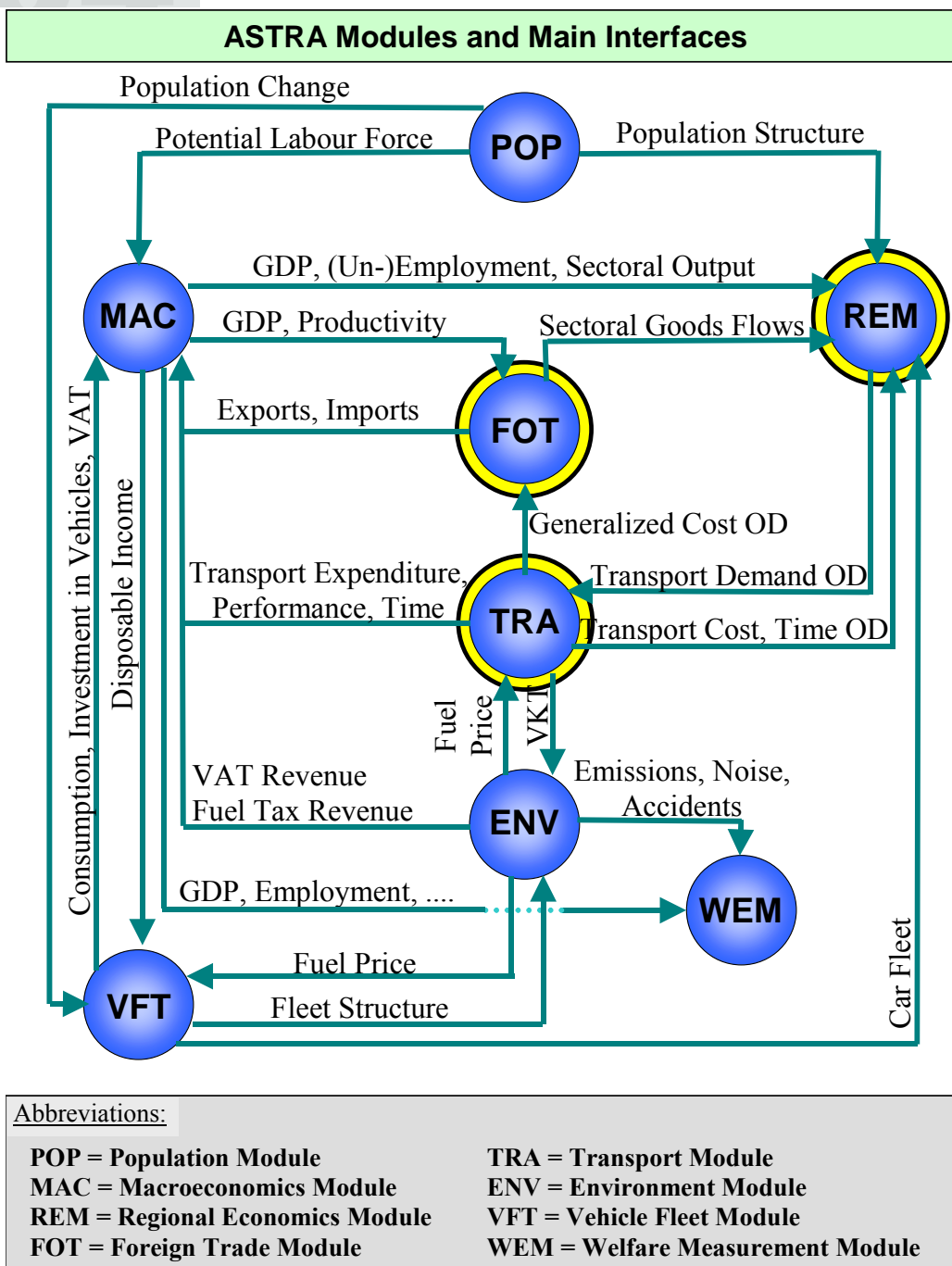

Figure 1: Overview on the ASTRA model

The ASTRA model comprises more than 5.000.000 objects implemented in the standard System Dynamics software package Vensim. Objects could be variables, which is equal to equations, constants or data input. More than 300.000 objects are level variables and in that sense are dynamic variables. Two major types of level variables can be distinguished: delay or lag variables and accumulating variables of which the former stand for the greater share of level variables in the model. One scenario simulation between 1990 and 2020 with yearly saving intervals of results generates 270 Mega-Byte of output data. About 12.000 time series are used to calibrate ASTRA for the period 1990 until 2000. All monetary values are calculated in real values of 1995 EUROS. Most variables are calculated net of all taxes and taxes are treated separately. The basic time period for most modules e.g. MAC, FOT, VFT is one year.

System Dynamics methodology is at first developed during the 1960ies by FORRESTER (1962, 1977). It rests on a few building blocks to construct a model, which are level and flow variables, auxiliary variables, parameters and, if using the graphical representation of a system dynamics model, connectors to describe the structure of the system. Mathematically a system dynamics model consists of non-linear differential equations that are computed by numerical integration since usually analytic solutions for the system of equations cannot be found (STERMAN 2000).

Construction of System Dynamics models assumes that the behaviour of a system is primary determined by its feedback mechanisms. *"The central concept that system dynamicists use to understand system structure is the idea of two-way causation or feedback."* (MEADOWS 1980 p.31). In the terminology e.g. used by KRUGMAN (FUJITA/KRUGMAN 2004) a feedback loop would be a *"circular causation of forward linkages [] and backward linkages []"* such that the concept of feedback loops is also present in new economic geography, but with different naming.

2 Description of the trade model

Foreign trade in the past decades was a major driver of economic growth. Within the EU15 the removal of trade barriers and improvement of transport connections even increased this driving effect. As such transport has always been acknowledged as important for trade relationships. To reflect this importance in ASTRA a trade model is implemented that incorporates transport as an influencing factor.

For the coming years the expectations remain that exports will constitute an important influence on growth. The accession of further countries to the EU will enforce this. Nevertheless, there could be differences in the sectoral structure of trade between current EU15 members and the rest-of-the-world. It could be expected that INTRA-EU15 trade in services is increasing importance compared with trade in goods sectors, while growth of trade of EU15 with countries outside the EU15 should be more balanced over all sectors. This picture is also drawn by the sectoral results of the ASTRA model for the sectoral growth of exports between 2000 and 2010, 2020 shown in Figure 2.

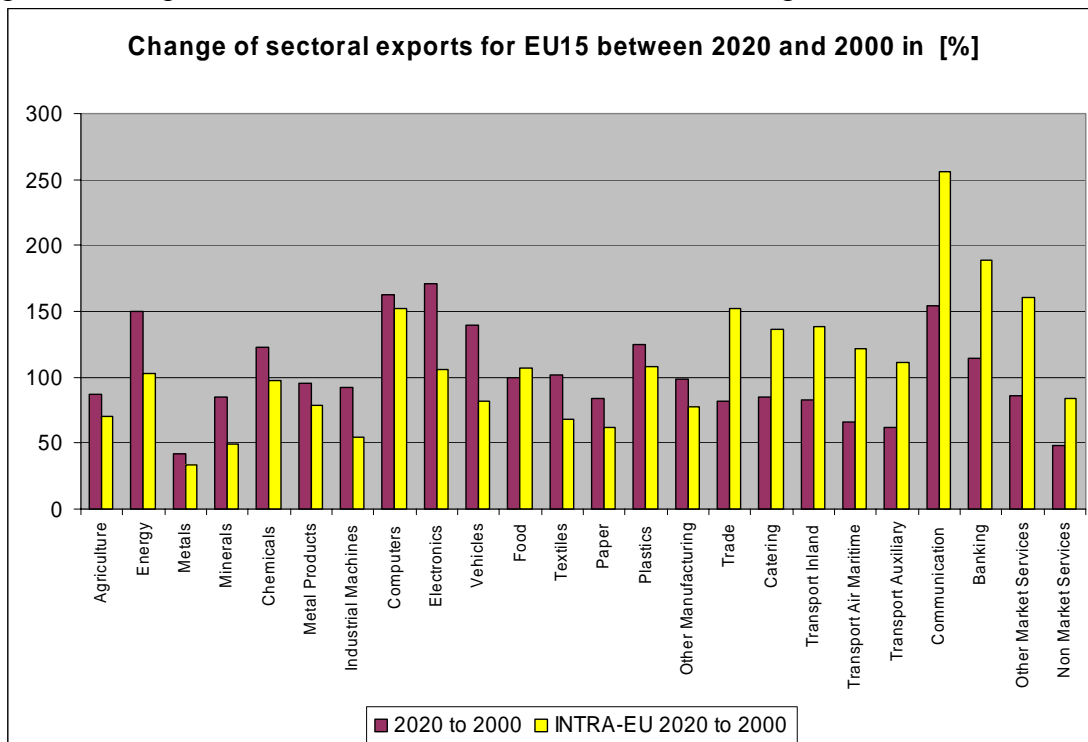

Figure 2: different sectoral structure of export growth for INTRA-EU and total EU exports

2.1 Overview on structure of the trade model

The foreign trade module (FOT) in ASTRA is split into two regionally different models of similar structure:

- INTRA-EU trade model that describes the sectoral trade between the EU15 countries and enables either to derive sectoral exports and sectoral imports of each country. Influences on trade considered in the model are: world GDP, GDP of importing country, relative sectoral productivity and transport.
- EU- to rest-of-the-world (EU-RoW) trade model that depicts the sectoral exports of EU15 countries to 12 rest-of-the-world regions. Imports in this EU-RoW model are only roughly modelled. Influences on trade considered in the model consist of: world GDP, GDP of importing country and relative sectoral productivity.

This paper is focussing on the INTRA-EU trade model as it incorporates the full trade and transport linkages. Also, depending on the country, INTRA-EU trade accounts for 60-80% of foreign trade of the EU15 member states. In ASTRA INTRA-EU export flows between the 15 European countries depend on four factors, amongst them transport. The rationale for the four factors is:

- World GDP growth: in the past export growth of most countries followed world GDP growth with surprising accuracy. Hence, it is considered as one influencing parameter for the export model.
- GDP growth of the importing country: as GDP reflects consumption and production processes of a country, growth of GDP is also associated with increased imports and hence it is used as a second influencing parameter.
- Labour productivity: reflects the competitive advantage in the sectoral relationship between two countries and as such it is influencing the trade flows between countries. In general this is expected to be the most important parameter, but ASTRA calibrations did not confirm this.
- Generalized cost of transport between two countries: generalised cost of transport, are an aggregate of transport cost and monetised travel time as transport decisions not only depend on cost but also on time conditions (ORTUZAR/WILLUMSEN 1998)¹. Generalized cost determines the resistance for exchange of goods and people between two trading partners. Hence, it should become an influence included in a trade model. Both, passenger and freight transport cost are considered as also for goods sectors it plays a role how salesmen or maintenance personal can reach foreign customers. This is demonstrated by the recent SARS crisis with the example of Southeast Chinese factories running out of input material because the businessman could not or did not want to travel there such that also the generalized cost of business trips play a role in establishing trade relationships. The model considers some weighting putting more emphasis on freight transport cost for goods sectors and more emphasis on passenger transport cost for service sectors.

Feedback loops, as the main building blocks of System Dynamics models, are formed out of causal structures. These structures can be visualised in a causal diagram with interconnections between the system elements (see *Figure 3*). Causal diagrams offer useful capabilities to analyse systems or to communicate system structures and mental models between modellers, analysts or decision-makers. They enable to capture quickly hypotheses about causes of dynamics. Causal diagrams are built out of four elements, only:

¹ In fact, further relevant conditions might exist e.g. reliability of transport, safety requirements. But these could not be reflected in ASTRA, yet.

(1) variables that are linked by (2) arrows, which in turn are identified by (3) a link polarity to show if the linked variables develop in parallel or in the opposite direction i.e. a positive polarity exists if when the cause is growing then also the affected variable is growing and vice versa. Depicted feedback loops are assigned a (4) loop identifier indicating if it constitutes a positive (reinforcing) loop or a negative (balancing respectively dampening) loop. Negative feedback loops include an odd number of negative link polarities.

The export feedback loop in *Figure 3* resembles very much to the Heckscher-Ohlin model of trade between two countries (HECKSCHER 1919). Country A is importing goods from country B, which appear as exports on the demand side of country B and increase GDP of B. Hence, country B increases imports, which in turn leads to growing exports of country A finally increasing the GDP of country A. This basic feedback loop is enforcing. However, one of its major influences is constituted by sectoral relative labour productivity between the two countries (circle 1). If country A increases productivity faster than B it will increase its exports to B and vice versa, while B will lose exports such that the loop set-up by mutual growth of GDP could be broken by reduced GDP of country B. This impact could be different for any of the 25 sectors of ASTRA.

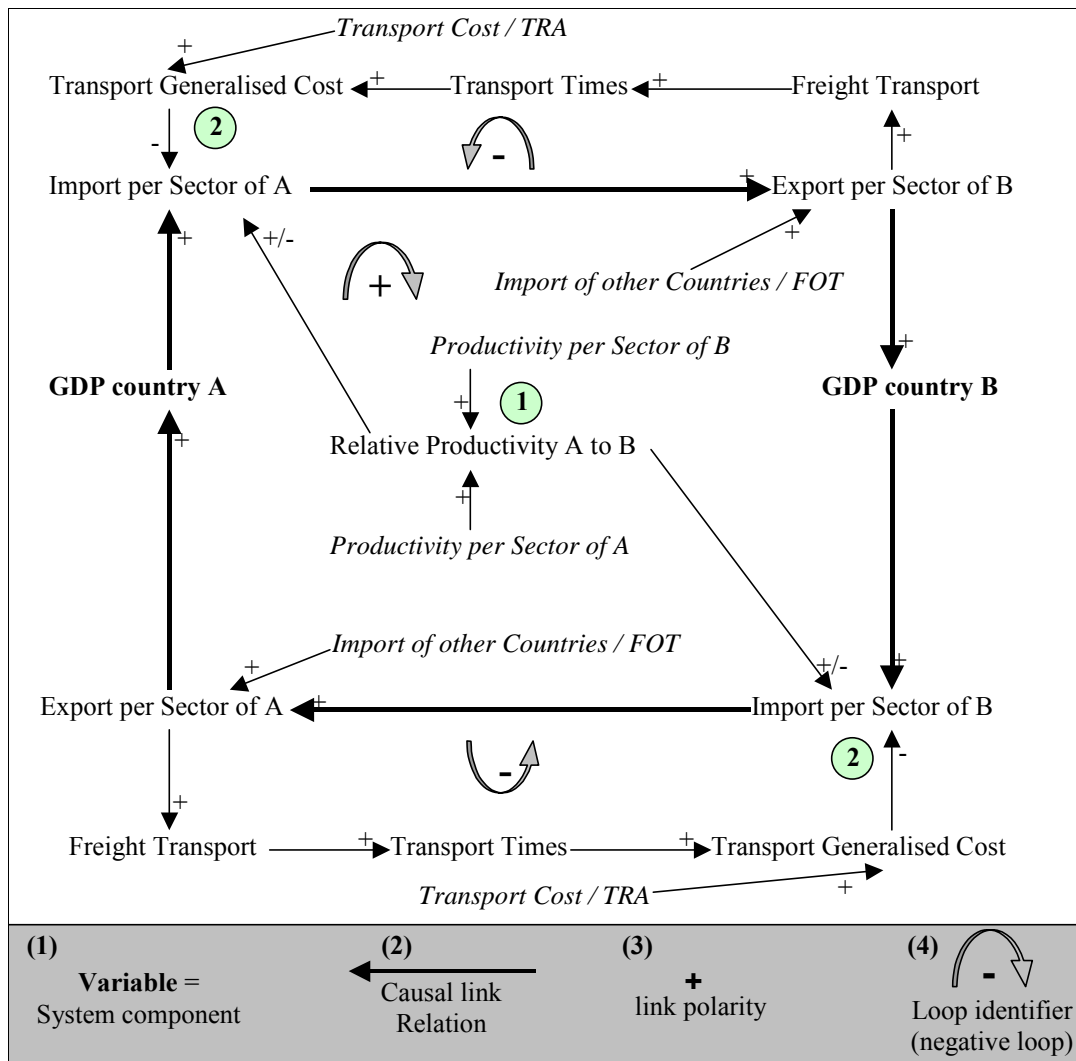

Figure 3: The main export feedback loop and its impacts from transport in ASTRA

A further influence on exports stems from transport. The quality of transport connections between countries A and B should affect exports. This quality could be expressed by generalised cost of transport between the two countries. Increased generalised cost would then shrink exports or at least lower export growth, which in turn leads to declining imports or at least slower growth of imports probably in both countries (circle 2). *Figure 3* indicates merely an influence from freight transport, but also changes of passenger transport could affect trade flows, which becomes obvious thinking about exports of service sectors like tourism as part of the catering sector in ASTRA or the transport service sectors themselves (see list of sectors in Table 2).

Resuming briefly the description of the trade – transport interactions, three model elements of ASTRA are composing the feedback loop between trade and transport that might be summarized by the following generic equations:

- Export model = $f(\text{transport, productivity, GDP, world GDP})$
- International transport model = $f(\text{trade respectively exports})$
- GDP model = $f(\text{trade, transport, consumption, investments, government expenditure, total factor productivity})$

The first of the three models is explained in more detail in the next sections. The other two models are outlined in the next two paragraphs.

National transport is modelled with the classical 4-stage transport model consisting of generation, distribution, modal-split and rough modal capacity models. Passenger generation depends on endogenously calculated socio-economic impacts e.g. employment status, income and car-ownership. National freight transport generation is endogenously driven by sectoral derived from input-output-table calculations. For international freight transport the first two stages, generation and distribution, are replaced by input from the export model, which provides sectoral goods flows in monetary terms that are then converted with volume-to-value ratios into three types of goods flows between countries and zones that then feed into international modal-split for each OD-pair. Finally, all flows are assigned to aggregate domestic networks per zone to model capacity limitations and travel time reactions of the various modes.

GDP accounts for the balanced result from the supply side model (potential output) and the demand side model (final demand). It depends on the macro-economic elements consumption, investments, government expenditure, employment, total factor productivity but also on transport. A rather direct link from transport is implemented via the modal expenditures for transport and vehicles that are part of consumption and investments, respectively. The indirect link runs via the trade model, which, as explained above, is also affected by transport.

2.2 Categories used in trade and transport model

The two major categories of ASTRA needed for trade and transport modelling are the spatial differentiation into EU15 countries (Table 1) with sub-categorisation into four functional zones per country (metropolises, high density, medium density, low density zones) and the categorisation into 25 economic sectors (Table 2) each dealt separately with in the trade model. For the EU-RoW trade model additionally a regional categorisation with 12 regions representing the rest-of-the-world countries is applied (Table 1).

Table 1: overview on EU15 countries and rest-of-the-world regions in the ASTRA trade models

Code	EU15 countries	Code	RoW regions
AUT	Austria	AUZ	Oceania
BLX	Belgium-Luxembourg	CEA_N	Northern Eastern European Associates
DNK	Denmark	CEA_S	Southern Eastern European Associates
ESP	Spain	CHI	China
FIN	Finland	EAS	East Asean Tigers
FRA	France	IND	India
GBR	United Kingdom	JAP	Japan
GER	Germany	LAM	Latin America
GRC	Greece	NAM	North America
IRL	Ireland	OEU	Other Europe
ITA	Italy	SEA	Southern European Associates
NLD	Netherlands	RotW	Rest-of-the-world
PRT	Portugal		
SWE	Sweden		

Table 2: overview on economic sectors following NACE-CLIO systematics²

Nr	Goods Sectors	Nr	Service Sectors
1	Agriculture, forestry and fishery products	17	Recovery, repair services, wholesale, retail
2	Fuel and power products	18	Lodging and catering services
3	Ferrous and non-ferrous ores and metals	19	Inland transport services
4	Non-metallic mineral products	20	Maritime and air transport services
5	Chemical products	21	Auxiliary transport services
6	Metal products except machinery	22	Communication services
7	Agricultural and industrial machinery	23	Services of credit and insurance institutions
8	Office and data processing machines	24	Other market services
9	Electrical goods	25	Non-market services
10	Transport equipment		
11	Food, beverages, tobacco		
12	Textiles and clothing, leather and footwear		
13	Paper and printing products		
14	Rubber and plastic products		
15	Other manufacturing products		
16	Building and construction		

Basic structure of both trade models is constituted by a three-dimensional trade matrix representing the sectoral flows between country pairs in value terms that are calculated on an annual base. An overview on the dimensions in the trade model is presented in Table 3.

Table 3: dimensional structure in both trade models in ASTRA

Model	Export-Index		Import Index		Sector Index		Matrix Elements
	Coverage	#	Coverage	#	Coverage	#	#
INTRA-EU trade	EU15 countries	14	EU15 countries	14	NACE-CLIO	25	4900
EU-RoW trade	EU15 countries	14	RoW regions	12	NACE-CLIO	25	4200

Further categories relevant for trade and transport modelling are the differentiation into transport modes, trip purposes, goods categories and transport distances as these are relevant for transport modelling (Table 4).

² NACE = General industrial classification of economic activities within the European communities, CLIO = Classification and nomenclature of input-output

Table 4: overview on differentiation of the transport model in ASTRA

Type of transport	Mode in ASTRA	Included modes	Trip purposes / Goods categories in ASTRA	Includes
Passenger	slow	walking, cycling	Business	Business trips, commuting trips
	car	car, sports utility vehicles (SUV)	Private	Shopping, education, leisure, visit relatives
	bus	scheduled bus, coach	Tourism	Holiday trips (more than one day)
	rail	tram, metro, heavy rail		
	air	scheduled flights, charter		
Freight	truck	light duty vehicles (LDV), heavy duty vehicles (HDV)	Bulk	Ores and metals, basic chemicals, fuel, coal
	rail	heavy rail, inland waterway	General cargo	Metal products, machines, vehicles, agriculture products
	ship	ocean shipping	Unitised	Food, textiles, paper, plastics, other manufacturing, computer, electronics

The transport model in ASTRA is not based on a transport network modelling approach, but on OD-matrices connecting origin and destination zones considering different distance bands for passenger and freight transport. In both cases transport cost and travel time of the medium distance band, enabling to reach neighbouring countries, and the long distance band, enabling to reach all destinations in all countries, are relevant for trade decisions.

Table 5: overview on characteristics of transport distance bands that are relevant for exports

Type of transport	Transport characteristics			Reach destinations in other countries	
	Travel distances	Available purposes / goods categories	Available modes	Reach neighbouring countries only	Reach all countries all zones
Passenger transport					
Medium DB (MD)	40 – 160 km	Business, private and tourism trips	car, bus, train	X	
Long DB (LG)	> 160 km	Business and tourism trips	car, bus, train, air		X
Freight transport					
Medium DB (MED)	150 – 700 km	all goods categories	all freight modes	X	
Long DB (LGD)	> 700 km	all goods categories	all freight modes		X

2.3 Equations of the INTRA-EU trade model

This section presents the equations of the INTRA-EU trade model for the four influencing factors of trade as listed in section 2.1. Labour productivity in ASTRA reflects the competitive advantage in the sectoral relationships between two countries. Changes of sectoral relative productivity between two countries increase export of the country that increases productivity faster. However, there should exist a lag between the productivity changes and the export changes. Since ASTRA does not include any exchange rates between countries it is implicitly assumed that either exchange rates are roughly stable or that relative productivity between two countries provides a sufficient proxy for exchange rates. Basic labour productivity development between 2000 and 2020 is taken exogenously from CHRISTIDIS et al. (2002) and altered endogenously in case of low unemployment levels that tend to exert pressures for increasing labour productivity to avoid labour shortages. Equation 1 presents the function resulting from the previous analysis.

$$\Delta rPRO(t)_{EC,EC2,s} = cPROD_{EC,EC2,s} * [(\Delta PRO(t - LAG_{EC,EC2,s})_{EC,s} - \Delta PRO(t - LAG_{EC,EC2,s})_{EC2,s})]$$

(eq. 1)

where: $\Delta rPRO$ = influence of relative sectoral productivity on exports [dmnl]
 $cPROD$ = calibrated coefficient for influence of productivity on export [dmnl]
 ΔPRO = change of productivity over a period of 1 year [dmnl]
 LAG = time lag between change of productivity and impact on exports [year]
 s = **index for 25 economic sectors**
 $EC2$ = **index for importing EU15 country**
 EC = **index for exporting EU15 country**³

GDP reflects consumption and production processes of a country. Both are associated with the demand for imported goods, such that growth of GDP usually will increase imports. Hence, development of GDP of the importing country of a trade relationship presents a second decisive factor for exports and imports respectively. Increased GDP growth of the importing country should accelerate the export growth for the exporter of the trade relationship and vice versa. This is reflected by equation 2.

$$\Delta GDP(t)_{EC,EC2,s} = cGDP_{EC,EC2,s} * \Delta iGDP(t)_{EC2}$$

(eq. 2)

where: ΔGDP = influence of GDP of importing country [dmnl]
 $cGDP$ = calibrated coefficient for influence of GDP on export [dmnl]
 $\Delta iGDP$ = change of GDP of importing country over a period of 1 year [dmnl]

Looking at long-run historical time series of exports and world GDP growth a strong correlation can be identified. Though on world level the causal relationship between world GDP growth and exports is rather from the latter to the former than the other way round. But on country level world GDP growth can have a separate influence not captured by productivity changes and country-based GDP growth. In general it can be assumed that positive changes of world GDP growth increase exports. Additionally, it seems that a threshold of world GDP growth exists, above which a positive influence of world growth on exports could be observed, while below it would be neutral or even lead to decreasing exports. This is confirmed on EU-RoW export relationships by the calibration with resulting values for the thresholds usually ranging from +0.5 to +1.5% world GDP growth. Finally, the speed of changes of world GDP growth can have an influence on exports, which could be explained by psychological factors. For instance a situation of 2% world GDP growth is much different when the growth was 1.9% or 1.2% half a year ago. So, the half yearly change of the GDP growth rate is also taken into account. Hence, the equation to describe the influence of world GDP growth on INTRA-EU exports looks as follows:

$$\Delta exWGDP(t)_{EC,EC2,s} = cWGDP_{EC,EC2,s} * [\Delta WGDP(t) - thWGDP + [\Delta WGDP(t) - \Delta WGDP(t - 0.5)]]$$

(eq. 3)

where: $\Delta exWGDP$ = influence of world GDP growth on exports [dmnl]
 $cWGDP$ = calibrated coefficient for influence of world GDP growth on export [dmnl]
 $\Delta WGDP$ = world GDP growth over a period of 1 year [dmnl]
 $thWGDP$ = threshold above which world GDP growth exerts a positive influence on exports [dmnl]

³ The indexes s , $EC2$ and EC are also present in most of the following equations. However, they are not listed in the list of variables to avoid space consuming and unnecessary doubling of text.

Since world GDP growth is not modelled in ASTRA it has to be taken exogenously. Figure 4 presents data and expected development of yearly world GDP growth rates until 2020. Data is used until 2000. After 2000 initially the results of the GEM-E3 general equilibrium world model have been used (CHRISTIDIS et al. 2002). However, they show a smooth and rather optimistic picture without considering any business cycles as have been observed for the early 1990ies. Using the trend from GEM-E3 should overestimate exports as the smooth and optimistic picture would project only periods with strong export growth. Hence, the picture is adapted to reflect two ten-year cycles of world GDP growth similar to the development in the 1990ies (Figure 4). This should provide a more moderate but also more realistic picture for the framework of export development in ASTRA.

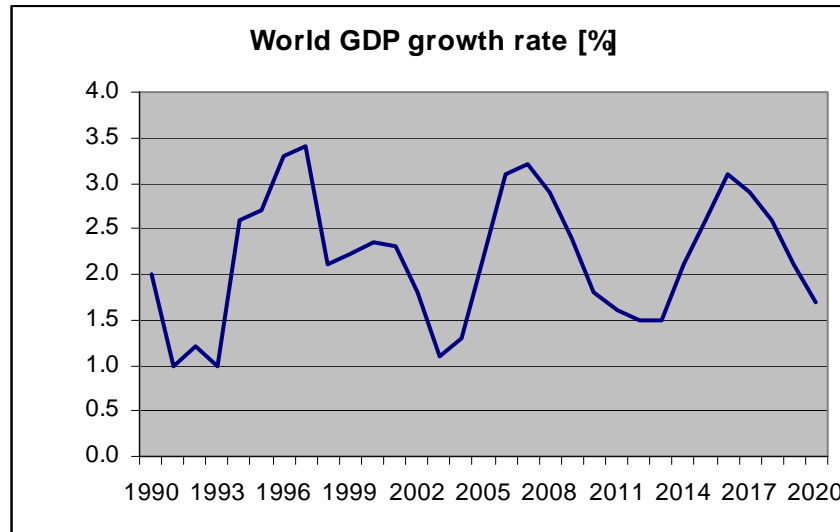

Figure 4: Data and assumed development of world GDP growth rate

Generalized cost of transport between two countries determines the major part of spatial resistance for exchange of goods and people between two countries.⁴ As STEININGER (2001) derives in an equilibrium setting "*positive transport costs can reduce trade flows. At the extreme, sufficiently high transport costs can eliminate trade...*". Hence, transport should become an influence included in a trade model. Both, passenger and freight transport generalised cost should be considered as also for goods sectors it plays a role how salesmen or maintenance personal could reach foreign customers. Vice versa for exports of services passenger transport should be more important e.g. for tourism. Hence, the model should consider some weighting putting more emphasis on freight transport cost for goods sectors and more emphasis on passenger transport cost for service sectors.

The basic calculation for average generalised costs between two countries is shown for freight transport in equation 4 (for passenger transport see equation 6). Generalised cost and tons are aggregated over modes and OD-functional zones and are then divided to calculate average generalised cost per country pair, which can be seen as an accessibility measure between the two countries. Accessibility is then smoothed since reactions to changes of accessibility occur spread over time, which is obvious if one looks at the example of introducing a transport pricing policy at one point of time. It will not happen that all reactions of exports appear immediately and one time step later all reactions are completed. Instead a medium term adaptation process will be started leading to new export relationships and possibly to altered location choices such that the adaptation process may take several years.

⁴ Further elements would e.g. be culture or language barriers, which are not considered in ASTRA.

$$sfGC(t)_{DB,GC,EC,EC2} = SMOOTH \left[\frac{\sum_{m,OC,DC} GC(t)_{DB,GC,m,EC,OC,EC2,DC}}{\sum_{m,OC,DC} TON(t)_{DB,GC,m,EC,OC,EC2,DC}}, RT \right] \quad (eq. 4)$$

- where: sfGC = smoothed and weighted averaged freight generalised cost per country pair [EURO/t]
 SMOOTH = vensim function providing smoothing and spreading of impacts over time [dmnl]
 GC = generalised cost per trip per OD-pair [Mio*EURO]
 TON = volume transported per OD-pair [Mio*t]
 RT = smooth time used here as reaction time of exports to changes in generalised cost. A reasonable value used in the model is 3 years implying that some changes appear directly but other changes occur after 3 years or later. The peak of yearly changes is then in the 3rd year.
 DB = index for freight distance bands (MED, LGD)
 GC = index for goods categories (BLK, GCG, UNT)
 m = index for freight modes (road, rail, ship)

Equation 5 describes the translation of the accessibility per country pair into an influence on sectoral exports. First, distance bands are weighted by assigning the longer distance bands a higher weight because the same relative change of generalised cost implies a higher absolute change for the longer distance bands, which would be relevant e.g. for time-savings that could be incorporated into an improved overall production process. Then the impact on goods sectors is weighted twice to reflect that exports of goods should be more dependent on freight transport than on passenger transport. Subsequent the exponential is taken to make the model more sensitive for larger changes such that marginal improvements e.g. of saving a few "seconds" become negligible and mainly significant changes are considered to alter exports. Finally, the change is multiplied with a calibrated coefficient taking into account the relationship between sectors and goods categories such that sectors producing bulk goods are affected by accessibility changes of bulk goods and accordingly for the other sectors. For freight influence on service sectors a combination of general cargo and unitised goods category is applied.

$$\Delta fGC(t)_{EC,EC2,s} = cGC_{EC,EC2,s} * \left[EXP \left[\frac{\sum_{DB} wDB_{DB} * \Delta sfGC(t)_{DB,GC,EC,EC2}}{\sum_{DB} wDB_{DB}} * wGS_s \right] - 1 \right] \quad (eq. 5)$$

- where: ΔfGC = influence of smoothed freight generalised cost on sectoral export [dmnl]
 cGC = calibrated coefficient for influence of freight generalised cost on export [dmnl]
 EXP = exponential function
 wDB = weight of distance bands weighting long distance band double [dmnl]
 $\Delta sfGC$ = change of smoothed freight generalised cost per country pair over a one year period [dmnl]
 wGS = weight of freight transport on sectors introduces higher weight of freight for goods sectors and vice versa lower weights for service sectors [dmnl]
 DB = index for freight long distance bands (MED, LGD)
 GC = index for goods categories that also links sectors with changes in specific goods categories e.g. bulk categories like mineral are only affected by cost changes for bulk goods transport.

For passenger transport the equation look similar with smoothed changes of generalised cost presented in equation 6 and the influence on exports in equation 7. The major

difference to freight transport is constituted by assigning higher weights for passenger transport impacts onto service sectors.

$$spGC(t)_{DB,EC,EC2} = SMOOTH \left[\frac{\sum_{m,OC,DC} GC(t)_{DB, m, EC, OC, EC2, DC}}{\sum_{m,OC,DC} TRIP(t)_{DB, m, EC, OC, EC2, DC}}, RT \right] \quad (eq. 6)$$

where: spGC = smoothed and weighted averaged passenger generalised cost of business trips per country pair [EURO/trip]
SMOOTH = vensim function providing smoothing and spreading of impacts over time [dmnl]
GC = generalised cost per trip per OD-pair [Mio*EURO]
TRIP = volume demanded per OD-pair [Mio*trips]
RT = smooth time used here as reaction time of exports to changes in generalised cost. A reasonable value used in the model is 3 years implying that some changes appear directly but other changes occur after 3 years or later.
DB = index for distance bands (MD, LG)
m = index for passenger modes (car, bus, train, air)
OC = index for origin functional zone (MPA, HDA, MDA, LDA)
DC = index for destination functional zone (MPA, HDA, MDA, LDA)

$$\Delta pGC(t)_{EC,EC2,s} = cpGC_{EC, EC2, s} * \left[EXP \left[\frac{\sum_{DB} wDB_{DB} * \Delta spGC(t)_{DB, EC, EC2}}{\sum_{DB} wDB_{DB}} * wPS_s \right] - 1 \right] \quad (eq. 7)$$

where: ΔpGC = influence of smoothed passenger generalised cost on sectoral export [dmnl]
cpGC = calibrated coefficient for influence of passenger generalised cost on export
EXP = exponential function
wDB = weight of distance bands weighting long distance band double [dmnl]
 $\Delta spGC$ = change of smoothed passenger generalised cost per country pair [dmnl]
wPS = weight of passenger transport on sectors introduces higher weight of passenger for service sectors and vice versa lower weights for goods sectors [dmnl]
DB = index for passenger distance band (MD, LG)

After all five influences on exports are derived the final impact on exports is calculated by equation 8, which commences from the export level in the previous period and adds a delta of exports on top. The delta could become negative and reduce exports.

$$Ex(t)_{EC,EC2,s} = Ex(t-dt)_{EC, EC2, s} * \quad (eq. 8)$$

$$(1 + (\Delta rPRO(t)_{EC, EC2, s} + \Delta GDP(t)_{EC, EC2, s} + \Delta exWGDP(t)_{EC, EC2, s} + \Delta fGC(t)_{EC, EC2, s} + \Delta pGC(t)_{EC, EC2, s}))$$

where: Ex = sectoral exports between two EU15 countries [Mio*EURO]
 $\Delta rPRO$ = influence of sectoral relative productivity [dmnl]
 ΔGDP = influence of GDP growth of importing country [dmnl]
 $\Delta WGDP$ = influence of world GDP growth [dmnl]
 ΔfGC = influence of changes in accessibility of freight transport [dmnl]
 ΔpGC = influence of changes in accessibility of passenger transport [dmnl]
s = index for 25 economic sectors
EC2 = index for importing EU15 country
EC = index for exporting EU15 country

Data collection of trade data for the calibration of the export model was the most demanding task in developing ASTRA, since the transport data could be obtained to large extent from the SCENES model (ME&P 2000). The major database for trade calibrations

is the OECD online database on international trade (OECD 2003). The database provides export-import data on a sectoral level of 63 sectors categorised by the Standard International Trade Classification Revision 2 (SITC Rev 2) that can be aggregated to agriculture, the 14 industry sectors and construction for ASTRA purposes. However, as construction exports are very small or zero, exports of this sector are assumed to be zero (it is rather difficult, though not impossible, to export a house or a road and construction consulting services would belong to sector 24 in ASTRA). Export data is prepared for the EU15 countries and all of the RoW regions. Processed and aggregated data for calibration consists for goods export of about 5000 time series and a lower number for services export as these are only available for EU15 countries and trade with North America and Japan (OECD 2002⁵). The number of processed raw data series amounts to several ten-thousands.

The sectoral calibration for each of the 4900 combinations (see Table 3) led to the following weights for the four factors that differ over time (less variance) and from country to country. On average world GDP has a weight of 20-50%. GDP of the importing country is in the range of 10 to 30%. Labour productivity has a weight of -30 to +30%. Negative values imply that a country is loosing exports because of competitive disadvantages. Passenger transport is estimated with -5 to 10% (depending if generalised cost increase or decrease) and freight with -10 to 0% (since freight generalised cost tend to increase).

2.4 EU to RoW trade model and aggregation

The influencing factors in the EU to rest-of-the-world trade (EU-RoW) model are similar to the INTRA-EU trade model, besides that it is excluding transport as an influencing factor as the spatial coverage of the transport model of ASTRA ends at the borders of the EU15 countries such that complete time and cost information would be missing to consider transport in EU-RoW model. Another difference to the INTRA-EU model accounts for that GDP of the RoW-regions is not modelled endogenously as ASTRA does not include models for the economies of these regions. Instead it is provided by exogenous inputs from CHRISTIDIS et al. (2002).

Finally, total sectoral exports of the EU15 countries are derived by aggregating sectoral exports between EU15 countries (INTRA-EU) with sectoral exports from EU15 countries to RoW regions (EU-RoW):

$$\text{totEx}(t)_{EC,s} = \sum_{EC2} Ex(t)_{EC, EC2, s} + \sum_{RoW} ExRoW(t)_{EC, RoW, s} \quad (\text{eq. 9})$$

where: totEx=	total sectoral exports of EU15 countries [Mio*EURO]
Ex =	sectoral exports between EU15 countries [Mio*EURO]
ExRoW =	sectoral exports between EU15 countries and RoW regions [Mio*EURO]
s =	index for 25 economic sectors
RoW =	index for importing region of the rest-of-the-world
EC2 =	index for importing country of the EU15 countries
EC =	index for exporting EU15 country

3 Model Analysis

The analysis of such a large model like ASTRA could not be performed on the base of the presented equations alone as together with the equations of not shown equations from other ASTRA modules these are too many and the dynamics of the various interconnected feedback loops are not approachable by an analytic procedure. Instead, model analysis

⁵ This represents the first rather comprehensive statistic on trade in services per partner country. So far, it is available for two years only such that for ASTRA only limited use could be made of it. Additionally, looking at trade in services some peculiarities can be observed e.g. looking at tourism it is not the traded good that moves from exporting country to customers in the importing country but the customer himself and on top of that he moves from importing country to exporting country.

focuses on undertaking model runs in which specific elements of the model are switched-off or parameters are varied. Especially the so-called with-and-without-tracing seems to be useful to analyse the export model. It means to switch off a single mechanism or a set of mechanisms during a model simulation. The resulting difference between a basic run (with) and the run excluding a mechanism (without) can be assigned as impact of the excluded mechanism. To be clear, this impact could not be identified from an analysis of the equation that is switched off, because it includes all secondary impacts caused by the excluded mechanism in any other part of the ASTRA model.

In the following two different analyses of this kind are presented. First, the link between transport generalised cost and export (see equation 8) is switched off and the aggregated impact on major economic variables for the EU15 countries is compared against the business-as-usual (BAU) scenario. Second, a pricing policy as defined in the European research project TIPMAC, which is aimed at implementing Social Marginal Cost Pricing (SMCP) for all transport modes, is introduced. The SMCP policy is designed to be fully-fledged by refunding the additional revenues from SMCP via reduced income tax. This policy and several variants, with variations of the SMCP charging level, are tested and their influences on exports and GDP are compared. Additionally, two artificial – since not fully-fledged - scenarios are analysed that either increase freight transport cost or passenger transport cost by +25%.

The BAU scenario for EU15 is outlined in brief: over the two decades from 2000 until 2020 the forecasted GDP grows by +54%, which is equivalent to an average annual growth rate of close to 2.2%. Exports of EU15 countries remain a driver of GDP growth with +111%, while full-time equivalent employment will increase only by +5.4% and population is slightly growing with +3.5%. Passenger transport performance (pkm) increases by +29% and freight transport performance (tkm) shows significantly larger growth with +94%. Technical progress concerning fuel efficiency could not cope with this increase of transport performance such that CO₂ emissions from transport grow by +31%.

The results for the first test simply excluding transport from exports in the BAU scenario are presented in Figure 5. In the first five years nearly no reaction can be observed. But after 1995 exports tend to grow strongly reaching until 2020 an increase of 6.3% compared to BAU scenario. This proves that transport constitutes a relevant factor in the export model. The direction of change showing an increase of exports not considering transport would be surprising. However, it becomes plausible considering that average transport cost in BAU scenario increase continuously such that excluding this negative impact (increased costs) clearly should lead to a more positive picture for exports. In Figure 5 it could also be observed that exports exert a significant impact on investment such that increasing exports leads to investments that are about +4.5% higher than in BAU. It is obvious that if with exports and investments two major macroeconomic variables develop significantly positive compared to BAU all other variables like GDP or employment show also positive reactions.

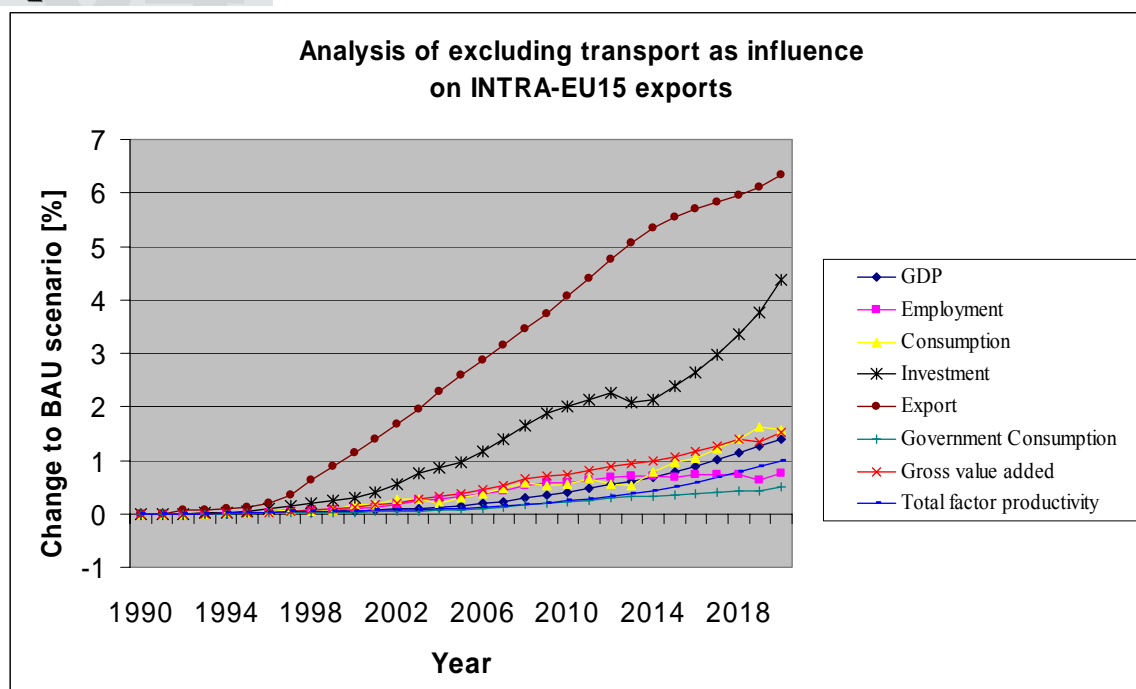

Figure 5: Macroeconomic impacts of excluding transport influences from INTRA-EU exports

This test also reveals the feedback from exports to transport as long distance freight transport with about +5% in 2020 is growing much stronger than short distance transport with less than +2%, where the +2% reflect the moderate change of GDP with +1.5%, while the +5% of long distance transport growth reflect the export change with more than +6%.

The second analysis concerning exports is related to the question how strong transport reactions to policies would influence exports. Baseline for the analysis is provided by an SMCP policy in accordance with the European White Paper on "European Transport Policy for 2010: Time to decide" (CEC 2001) and elaborated on in PONTI et al. (2002). Implemented averaged SMCP charging levels per mode and per country are shown in Table 8. Existing transport charges e.g. road tolls are abolished, such that the scenario is called SMCP-Tolls. In general the SMCP policy is implemented starting in 2002 and reaching its full implementation in 2004. The policy generates total annual SMCP revenues of about 310 Bio EURO in the first years after implementation with a growing tendency due to continuing transport growth.

Table 6: SMCP in eurocents(2002)/pkm (passengers), eurocents(2002)/tkm (freight)

P/G	MODE	ALL	AT	BE	DE	DK	FI	FR	GR	IR	IT	LU	NL	PT	SP	SW	UK
Goods	Hv. Truck	2.40	2.73	2.52	2.03	1.90	1.85	2.60	1.99	1.97	3.98	3.19	2.66	2.05	2.57	2.52	1.32
Goods	Med.Truck	6.48	7.37	6.81	5.47	5.13	5.01	7.03	5.39	5.32	10.7	8.61	7.19	5.54	6.95	6.81	3.57
Goods	Rail	0.28	0.31	0.35	0.35	0.28	0.15	0.46	0.19	0.22	0.34	0.35	0.32	0.18	0.22	0.17	0.25
Goods	IWW	0.26	0.35	0.38	0.31		0.12	0.38			0.31	0.38	0.34			0.15	0.23
Goods	SSS	1.21		2.01	1.20	0.58	0.25	2.56	2.30	0.37	1.73		0.38	0.72	0.60	0.70	0.43
Passengers	Car	5.94	7.36	4.61	7.13	5.23	4.31	7.70	5.71	5.11	6.54	8.61	6.47	4.49	5.42	3.33	3.07
Passengers	Bus/Coach	2.49	3.13	3.21	2.79	2.06	1.39	3.39	2.15	1.64	2.86	3.56	2.76	1.67	2.08	1.57	2.42
Passengers	Train	1.56	2.07	1.83	1.72	1.77	0.76	1.68	1.00	1.36	1.62	1.83	1.69	1.01	1.18	1.90	1.48
Passengers	Ferry	1.90	-	2.14	2.07	2.18	1.80	2.02	1.23	1.74	1.99	2.14	2.01	1.26	1.44	1.89	1.80
Passengers	Air	3.73	3.93	4.07	4.03	3.88	3.39	3.93	2.40	3.18	4.27	3.84	6.44	2.49	2.76	3.32	3.64

Source: PONTI et al. (2002); IWW = Inland Waterway; SSS = Short Sea Shipping (only applied to first and final 25kms)

Figure 6 shows that exports in SMCP-Tolls scenario decrease by more than -3.3% compared to BAU reaching its lowest level in 2013 about 9 years after the policy implementation. Applying with-and-without tracing by excluding transport from export influences in equation 8 would lead to the blue curve which shows only minor decrease caused by the remaining endogenous impacts on exports i.e. GDP change and change of relative productivity between countries. It can be observed that the reaction of exports to transport starts nearly immediately as costs are increased from the beginning of 2002 onwards until 2004. However, the difference of export changes in 2004 reaches -0.18% only though the policy is fully implemented at the beginning of 2004. This can be identified by the cost peak of average road cost in 2004 on the right hand side of Figure 6. Nevertheless, neither the impact chain on the export changes nor the cost changes are run through completely until 2004. Exports, including transport influences, change significantly at least until 2010 due to lags in the restructuring of trade relations. The reactions on the side of average transport costs settle in 2006 meaning that at this point of time modal shifts and changes of distributions found a balance such that any further changes cause only marginal advantages. Nevertheless, the continuous decrease of average cost for road and rail shows that continuous improvements by shifting modes or destinations are still ongoing. Concluding export reactions to transport changes occur within a time period of less than one year up to five years.

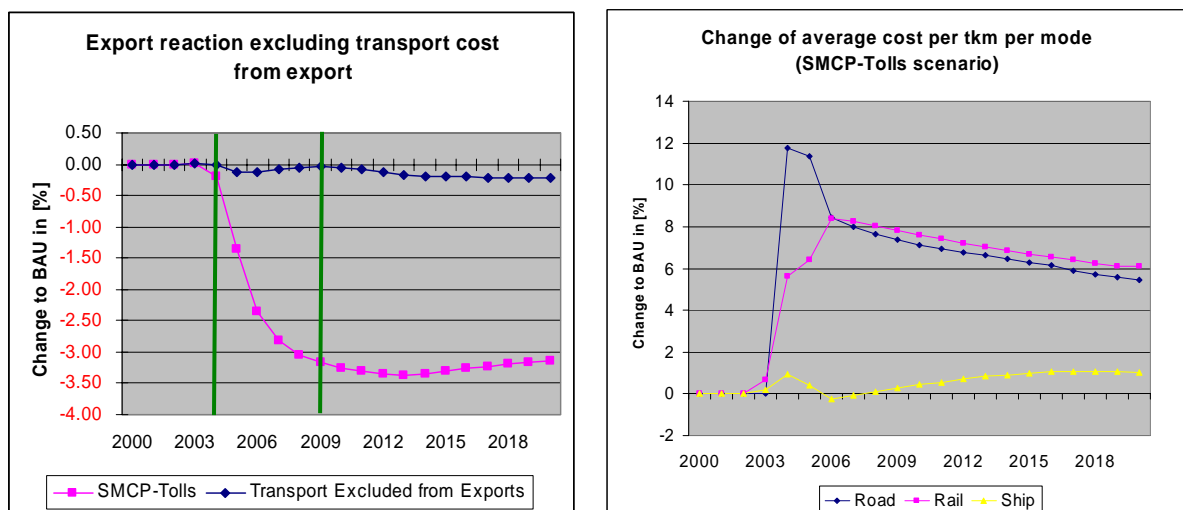

Figure 6: Change of exports in SMCP-Tolls and if transport impact is excluded from SMCP-Tolls

The following analysis presents reactions of exports and GDP to different variants of the SMCP-Tolls scenario all compared to BAU scenario. The five alternative scenarios comprise:

- SMCP-Tolls+Low: reduced SMCP charging levels;
- SMCP-Tolls-Taxes: fuel taxes are also abolished;
- SMCP+onTOP: neither tolls nor fuel taxes are abolished
- Freight +25%: freight cost are linear increased between 2000 and 2002 by +25%.
- Passenger +25%: passenger cost are linear increased between 2000 and 2002 by +25%.

Figure 7 presents the changes of exports and GDP for EU15 over time. The lower SMCP charging levels (SMCP-Tolls+Low, SMCP-Tolls-Taxes) lead to less reduced exports, while the higher charging level (SMCP+onTOP) enforces the loss of export

growth, as expected. The time structure of export changes reveals similar patterns for all strategies, while for GDP differences can be observed that would not stem from the changes in exports, but are caused by reactions of other parts of ASTRA. Besides the transport – export – (investment) – final demand interaction in the focus of this paper several other relevant mechanisms are identified (SCHADE 2004). The two most relevant are firstly, the modal-shift of freight transport that increases freight transport times and reduces total factor productivity, which considers that freight transport constitutes a part of today's production processes. Secondly, the modal-shift of passenger transport towards transport services lead to sectoral shifts of consumption and investment with consequences on final demand, value-added and employment. In fact, GDP in some scenarios reacts even positive, especially if losses of exports are low while other mechanisms unfold strong positive impacts. Noticeable remains the difference in freight and passenger +25%-cost increase scenarios, where exports are decreased stronger by the passenger scenario e.g. due to the higher share of transport cost compared to the share of transport times on generalised cost for passenger, while GDP is affected stronger by the freight scenario due to the larger impact of freight on output and productivity.

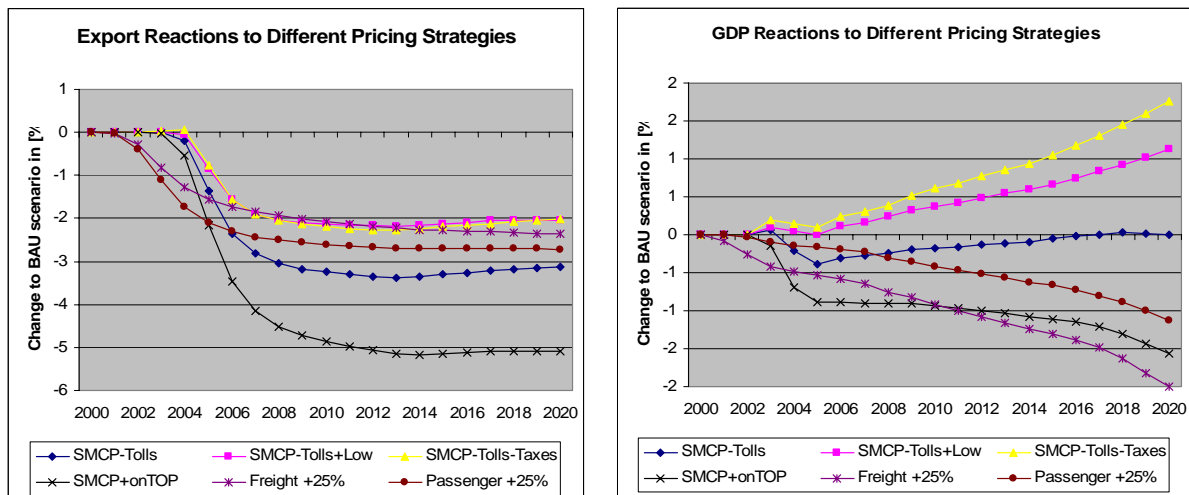

Figure 7: Change of exports and GDP for EU15 with different pricing strategies in ASTRA

Table 7 presents results for pricing strategies on country level for GDP and export changes compared to BAU. First to note should be that in most policies winners and loser could be identified. In case of the scenarios including the abolishment of existing tolls this constitutes one major reason for the differences as this implies for those countries that had previously tolls implemented that their transport cost are not increasing or are even decreasing e.g. Austria, Portugal. Other causes for differences are in case of significantly reduced imports the substitution of imported consumption goods by domestic goods e.g. relevant for positive results of Belgium-Luxemburg; or the simultaneous change into positive direction for all relevant mechanism unfolding positive synergies e.g. for Portugal; respectively vice versa the simultaneous change into negative direction e.g. for the Netherlands, though in the latter case the negative impacts might be exaggerated by ASTRA.

Table 7: changes of GDP and exports on country level with different pricing strategies

Scenario	SMCP-Tolls		SMCP-Tolls+Low		SMCP-Tolls-Taxes		SMCP+onTOP		Freight +25%		Passenger +25%	
	GDP	Exp	GDP	Exp	GDP	Exp	GDP	Exp	GDP	Exp	GDP	Exp
Austria	3.71	-2.44	4.87	2.24	5.01	0.62	-2.42	-10.56	-3.62	-5.62	-1.54	-5.84
Belgium-Luxembourg	0.58	-3.68	-0.02	-3.86	1.13	-2.60	1.26	-3.93	0.40	-1.40	1.92	-2.11
Denmark	-0.94	-1.73	-0.66	-1.44	-0.33	-0.88	-1.29	-2.11	-0.58	-1.21	-0.56	-1.85
Spain	-4.15	-1.29	1.20	2.66	2.63	1.27	-6.38	-5.15	-2.00	-3.03	-1.15	-2.77
Finland	2.97	-1.38	2.62	-1.15	4.32	-1.25	2.92	-1.25	0.65	-0.84	-0.70	-2.71
France	-0.13	-1.27	2.74	0.94	1.80	0.11	-4.32	-5.83	-6.18	-4.15	-2.48	-2.80
United Kingdom	1.72	0.48	1.15	0.06	2.81	1.08	1.60	0.53	-0.67	-1.25	-0.59	-1.32
Germany	0.83	-2.00	0.72	-1.91	1.71	-1.51	0.30	-2.43	-0.69	-0.69	-0.70	-2.00
Greece	-3.27	0.08	-0.47	0.23	0.26	0.49	-3.32	-0.31	0.44	-0.96	-0.63	-0.22
Ireland	-0.04	-0.93	-0.26	-1.08	1.35	-0.48	-0.14	-1.09	0.25	-1.44	-0.24	-1.79
Italy	-0.73	-3.66	0.75	-0.69	0.76	-2.75	-2.28	-7.11	-2.12	-3.20	-1.08	-2.51
Netherlands	-5.42	-14.57	-5.54	-14.84	-4.25	-12.46	-6.08	-15.64	-1.35	-3.35	-1.74	-5.74
Portugal	7.09	1.44	7.58	1.49	4.45	0.83	5.34	-0.47	0.79	-0.33	-1.28	-1.39
Sweden	3.71	-1.13	3.66	-0.95	7.16	-0.66	3.51	-1.03	0.99	-1.51	-1.62	-1.68

Source: ASTRA results

Figure 8 presents for one of the pricing strategies the development of total exports per country if freight transport costs for all modes are linearly increased by +25% from 2000 until 2002 reaching the full cost increase in 2002. The vertical thick line indicates the year 2002 in which for all countries the export reactions are below a decrease of -0.5%. One group of countries including e.g. Germany and Finland shows a stabilisation of changes of exports until about 2008. Another group including Italy and the Netherlands is decreasing exports compared to BAU until 2014 and then is stabilising. France reveals an s-shaped decline with a first stabilisation at 2008 and a second period of reduction of export growth after 2016. Roughly spoken in the first decade until 2010 it seems that the export related changes dominate the reactions with a delayed reaction of exports of two to six years after the cost increase. This is similar in structure but different in level of export changes for all countries. After 2010 a variety of longer term reactions can be identified that is due to different reactions in the transport system e.g. different thresholds of travel times for the different modes at which competing modes become attractive, to the economic performance of main trading partners of each country or to internal structures of the national economies e.g. on how much export changes or modal-shifts influence investments.

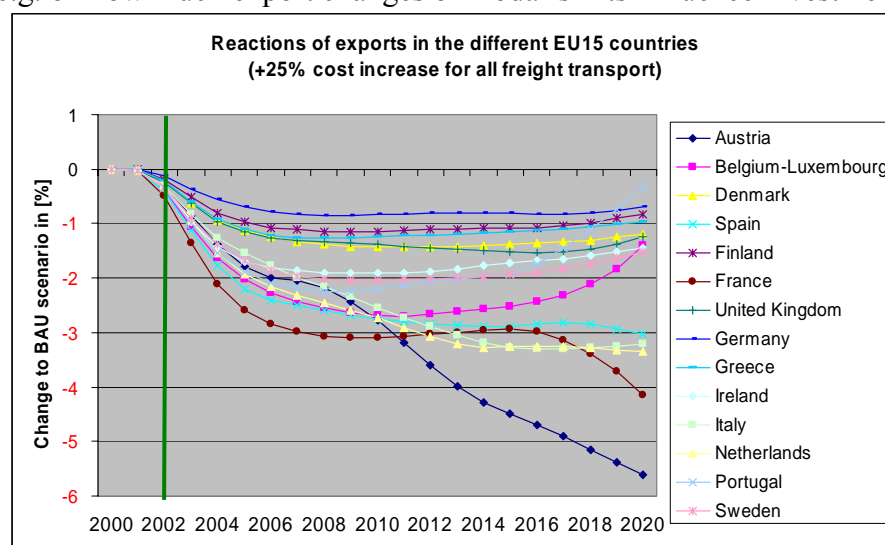

Figure 8: reactions of total exports in the different countries to a +25% increase of freight transport cost for all modes

The analysis concludes with a presentation of sectoral export changes on EU15 level in the freight and passenger 25%-cost increase scenarios. The picture concerning the goods sectors reveals some heterogeneity since some of them react stronger to freight cost increases, while others are even more affected by passenger cost increases, which is either an outcome of the calibration and the fact mentioned above that +25% cost increase for passenger transport leads to higher impacts on generalized cost than the same cost increase for freight since for passenger transport cost covers a larger share of total generalised cost than time. An expectation that could not be confirmed by these results would be that sectors producing bulk goods are more affected by transport cost changes than other sectors as the share of transport cost is larger to them than to other sectors. It seems that the time component of generalised cost, which is more important for sectors producing higher value goods outweighs the cost sensitivity of bulk producing sectors. I.e. modal-split changes towards slower modes due to cost changes could have a stronger impact on sectoral exports than the cost changes themselves.

Table 8: sectoral export changes for +25% cost increase either for freight or passenger transport
Change to BAU scenario in 2020 in [%]

Goods Sectors	Freight +25%	Passenger +25%	Service Sectors	Freight +25%	Passenger +25%
Agriculture, forestry and fishery products	-4.42	-3.94	Recovery, repair services, wholesale, retail	-1.49	-3.45
Fuel and power products	-2.59	-3.94	Lodging and catering services	-1.38	-3.90
Ferrous and non-ferrous ores and metals	-4.14	-3.63	Inland transport services	-1.42	-5.29
Non-metallic mineral products	-2.04	-1.94	Maritime and air transport services	-1.01	-2.74
Chemical products	-1.81	-1.03	Auxiliary transport services	-1.56	-4.16
Metal products except machinery	-2.21	-2.72	Communication services	-1.28	-0.92
Agricultural and industrial machinery	-2.39	-2.72	Services of credit and insurance institutions	0.02	0.32
Office and data processing machines	-3.07	-1.59	Other market services	-0.93	-2.45
Electrical goods	-1.56	-2.32	Non-market services	0.52	0.63
Transport equipment	-1.74	-1.97			
Food, beverages, tobacco	-5.23	-6.75			
Textiles and clothing, leather and footwear	-2.72	-3.18			
Paper and printing products	-3.04	-2.96			
Rubber and plastic products	-1.85	-1.60			
Other manufacturing products	-3.79	-3.59			

Source: ASTRA results

4 Conclusions

The paper presents the interaction between trade and transport as part of a wider economy – transport – environmental modelling framework provided by the ASTRA model. The model represents an integrated dynamic approach to describe the interactions between transport and the economy over time and space to analyse the impacts of the European transport policy. Since, trade and transport form important drivers of these interactions the model includes feedback loops that aspire to reflect the dynamics between trade and transport.

The trade and transport model is analysed by with-and-without tracing and by implementing policy variants that follow European transport policy strategies. The former analysis confirms that increasing transport cost would have a dampening impact on trade, if no accompanying measures are taken or are considered, respectively.

However, switching from static to dynamic context and from partial policies towards fully-fledged policies additional dynamics or mechanisms could unfold and compensate for the loss of exports. Which mechanisms become important for a country, as the smallest regional level considered in this paper, depends on the endowment with mechanisms of each country. Potentially relevant mechanisms identified in ASTRA would be:

- sectoral reactions of trade relationships;
- modal-shifts of
freight transport affecting generalised cost of trade relationships and transport times with their impact on total factor productivity;
passenger transport affecting sectoral consumption and investment;
- thresholds of modal choice and redistribution decisions;
- shifts between imported consumption goods and domestic consumption goods;
- synergies between the various mechanisms.

Country level is chosen for the analysis since the transfer of sectoral export reactions in ASTRA from country level onto the level of functional zones, that would correspond to NUTS-II level, follows a simple shift-and-share approach with an exogenous consideration of agglomeration effects that slightly increase the importance of metropolis and higher density zones over time. This procedure should be endogenised to improve the analytic capabilities of ASTRA with respect to the finer distribution of spatial impacts of transport policies.

Anyhow, the analysis confirms that considering dynamics, which may unfold over years, and fully-fledged policies, instead of partial policies, both are of key importance to analyse and derive the reactions of trade, transport and economic development to larger scale transport policies. Within this context the straightforward conclusion that increased transport cost would hamper economic growth due to decreased exports, could be rejected in cases when the fully-fledged policy triggers significant compensating mechanisms like increasing consumption. A pre-requisite to detect potential compensating mechanisms would be that integrated economy – trade – transport models are applied.

References

CEC - Commission of the European Communities, 2001). European transport policy for 2010: Time to decide, White Paper, Brussels.

Christidis, P., Hernandez, H., Lievonon, J., 2002. Impact of technological and structural change on employment: Prospective analysis 2020 – background Report, EU publication-nr EUR 20258 EN, Report on behalf of the European Parliament, Seville.

Forrester, J.W., 1962. Industrial Dynamics, MIT Press, John Wiley & Sons, 2nd edition, New York.

Forrester, J.W., 1977. Principles of Systems, MIT Press, Cambridge MA.

Fujita, M., Krugman, P., Venables, A.J., 1999. The spatial economy: Cities, regions and international trade, MIT Press, Cambridge MA.

Fujita, M., Krugman, P., 2004, The new economic geography: Past, present and the future, in: Papers in Regional Science, 83, 139-164.

Heckscher, E., 1919. The Effect of Foreign Trade on the Distribution of Income, in: Ekonomisk Tidskrift, pp. 497-512.

ME&P, 2000. SCENES European Transport Forecasting Model and Appended Module: Technical Description, Deliverable D4 of SCENES project funded by the European Commission 4th RTD framework, Cambridge.

Meadows, D.H., 1980. The Unavoidable A Priori, in: Randers J (ed) Elements of the System Dynamics Method, Productivity Press, Cambridge.

OECD - Organisation for Economic Co-operation and Development, 2002. OECD Statistics on International Trade in Services: Partner Country Data and Summary Analysis 1999-2000, Paris.

OECD - Organisation for Economic Co-operation and Development, 2003. OECD Online Statistics. <http://cs4-hq.oecd.org/oecd/>.

Ortuzar, J.D., Willumsen, L.G., 1998. Modelling Transport, second edn, John Wiley & Sons, New York.

Ponti, M., Maffii, S., Borgnolo, C., Pastori, E., Pasti, G., 2002. Common assumptions and scenarios, Deliverable D1 of the TIPMAC project funded by the European Commission 5th RTD framework, Milan.

Samuelson, P.A., 1954. The Transfer Problem and Transport Costs; II: Analysis of Effects of Trade Impediments, in: The Economic Journal, 64, 264-289.

Schade, W., 2004. Strategic Sustainability Analysis: concept and application for the assessment of the European Transport Policy, Dissertation thesis, publication forthcoming in Nomos Verlag, Baden-Baden.

Schade, W., Fiorello, D., Martino, A., 2002. ASTRA Model Update: Description of the ASTRA-T model, Deliverable D3 of the TIPMAC project funded on behalf of the European Commission 5th RTD framework, Karlsruhe.

Steininger, K., 2001. International Trade and Transport – Spatial Structure and Environmental Quality in a Global Economy, Edward Elgar, Cheltenham.

Sterman, J.D., 2000. Systems Thinking and Modeling for a Complex World, Irwin McGraw-Hill, Boston.

Venables, A.J., Gasiorek, M., 1999. The Welfare Implications of Transport Improvements in the Presence of Market Failure, Report to the UK SACTRA Committee, London.

Waldorf, B.S., 2004. Path-breaking books in regional science, in: Papers in Regional Science, 83, 59-89.

Wilson, A.G., 1970. Entropy in urban and regional modelling, Pion, London.